



Trix by Fibre ⚡ood

Trix by Fibre ood



XS - XXXL

Planning a party? Or simply fancy an extravagant look? This ruffle dress will be the eye-catcher in your summer wardrobe. The number of layers, that's up to you: go all the way, and you'll end up with a sensational maxi dress. Lose some layers and you'll have a midi dress, a mini dress or simply a top. The rectangular neckline and 3/4 balloon sleeves (with inner sleeves) top off this tropical treat.



size chart (in inches)

size	XS		S		M		L		XL		XXL		XXXL		
	0	2	4	6	8	10	12	14	16	18	20	22	24	26	28
body height	5' 25"	5' 38"	5' 45"	5' 48"	5' 51"	5' 54"	5' 58"	5' 61"	5' 64"	5' 64"	5' 64"	5' 64"	5' 64"	5' 64"	5' 64"
B (bust)	29.9	31.5	33.1	34.6	36.2	37.8	39.4	40.9	43.3	45.7	48	50.4	52.8	55.1	57.5

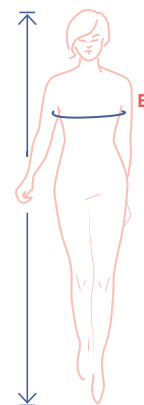

Choose your size based on the [bust measurement](#). Pick the size that is the best match for your bust. Then, check the hip measurements in the table below to be sure there is sufficient room at the hips.

pattern measurements (in inches)

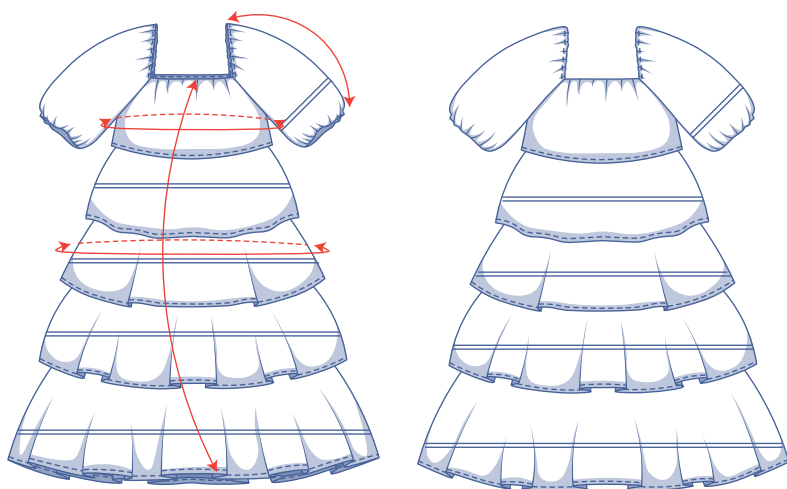

This chart's measurements are the pattern measurements based on the fabric type and serve as a reference. Ease has been added to the width measurements (in addition to the exact body measurements) for a more comfortable fit. [Trix is designed to have a relaxed cut.](#)

== shorten or lengthen the pattern here

size	XS	S	M	L	XL	XXL	XXXL
maxi dress length	49.3	49.6	50	50.4	51.7	52.2	52.7
midi dress length	37.1	37.5	37.7	38.1	39.4	40	40.5
mini dress length	26.8	27.2	27.5	27.9	29.2	29.7	30.3
top length	18.1	18.4	18.8	19	20.4	20.9	21.5
sleeve length	17	17	17	17	17	17	17
bust	32.3	35.4	38.6	41.7	45.7	50.4	55.1
hips	38.8	41.9	45.1	48.2	52.2	56.9	61.6

Compare the stated lengths to the measured or desired lengths. [Lengthen](#) or [shorten](#) the dress and/or sleeves by cutting the pattern pieces at the indicated double lines. Then either increase the distance between the cut pieces by the desired amount (to lengthen) or overlap the pieces (to shorten). Make sure that the CF and CB lines and the side seams are always straight.

IMPORTANT

Adjust the amount of fabric to be used based on these alterations.

notions



- Thread
- Stay tape: max. 5/6 yd
- Elastic cord (Ø 5/8"): see table
- Fabric: see table

elastic cord		XS	S	M	L	XL	XXL	XXXL
length per sleeve	yd	0.30	0.31	0.31	0.31	0.31	0.32	0.32
total length	yd	0.60	0.62	0.62	0.62	0.62	0.64	0.64

fabric use, maxi dress		XS	S	M	L	XL	XXL	XXXL
fabric width 43"	yd	7	7 ¼	8	8	8 ½	8 ¾	9 ¼
fabric width 55"	yd	5 ½	5 ¾	6 ¾	7	7 ¾	8	9

The corresponding fabric layout can be found on page 6 of these sewing instructions.

fabric use, midi dress		XS	S	M	L	XL	XXL	XXXL
fabric width 43"	yd	5 ½	5 ¾	6 ¼	6 ½	6 ½	6 ¾	7 ¼
fabric width 55"	yd	4	4 ¼	4 ¾	4 ¾	5 ¼	5 ½	6 ½

fabric use, mini dress		XS	S	M	L	XL	XXL	XXXL
fabric width 43"	yd	4	4	4 ½	4 ¾	5	5	5 ½
fabric width 55"	yd	3 ¼	3 ¼	3 ¾	3 ¾	4 ¼	4 ½	4 ¾

fabric use, top		XS	S	M	L	XL	XXL	XXXL
fabric width 43"	yd	2 ¾	3 ¼	3 ¼	3 ½	3 ¾	3 ¾	4
fabric width 55"	yd	2 ¼	2 ½	2 ½	2 ¾	3	3 ¼	3 ½

fabric advice



This dress is a real eye-catcher when the layers sway with your every step. So choose a supple fabric like (viscose) crêpe, lyocell, double gauze, mousseline or chambray. Popular seersucker gives a really lovely effect as well.

pattern pieces & seam allowances (in inches)

To sew the garment as described in the instructions, draw the illustrated seam allowances around the paper pattern pieces before cutting them out. If you are using a PDF pattern, the pattern can be printed with or without seam allowance. To find out more, watch [video](#).



1. front: 1x on the fabric fold
2. lining F: 1x on fabric fold
3. back: 1x on the fabric fold
4. lining B: 1x on fabric fold
5. outer sleeve: 2x
6. inner sleeve: 2x
7. ruffle 1: 2x on fabric fold
8. lining 1: 2x on fabric fold
9. ruffle 2: 2x on fabric fold
10. lining 2: 2x on fabric fold
11. ruffle 3: 2x on fabric fold
12. lining 3: 2x on fabric fold
13. ruffle 4: 2x on fabric fold

Tip!

Trix can be made in a number of different ways. You need all pattern pieces for the maxi dress. Use pattern pieces 1 up to and including 11 for the midi dress. For the mini dress use pattern pieces 1 up to and including 9. For the top use pattern pieces 1 up to and including 7.

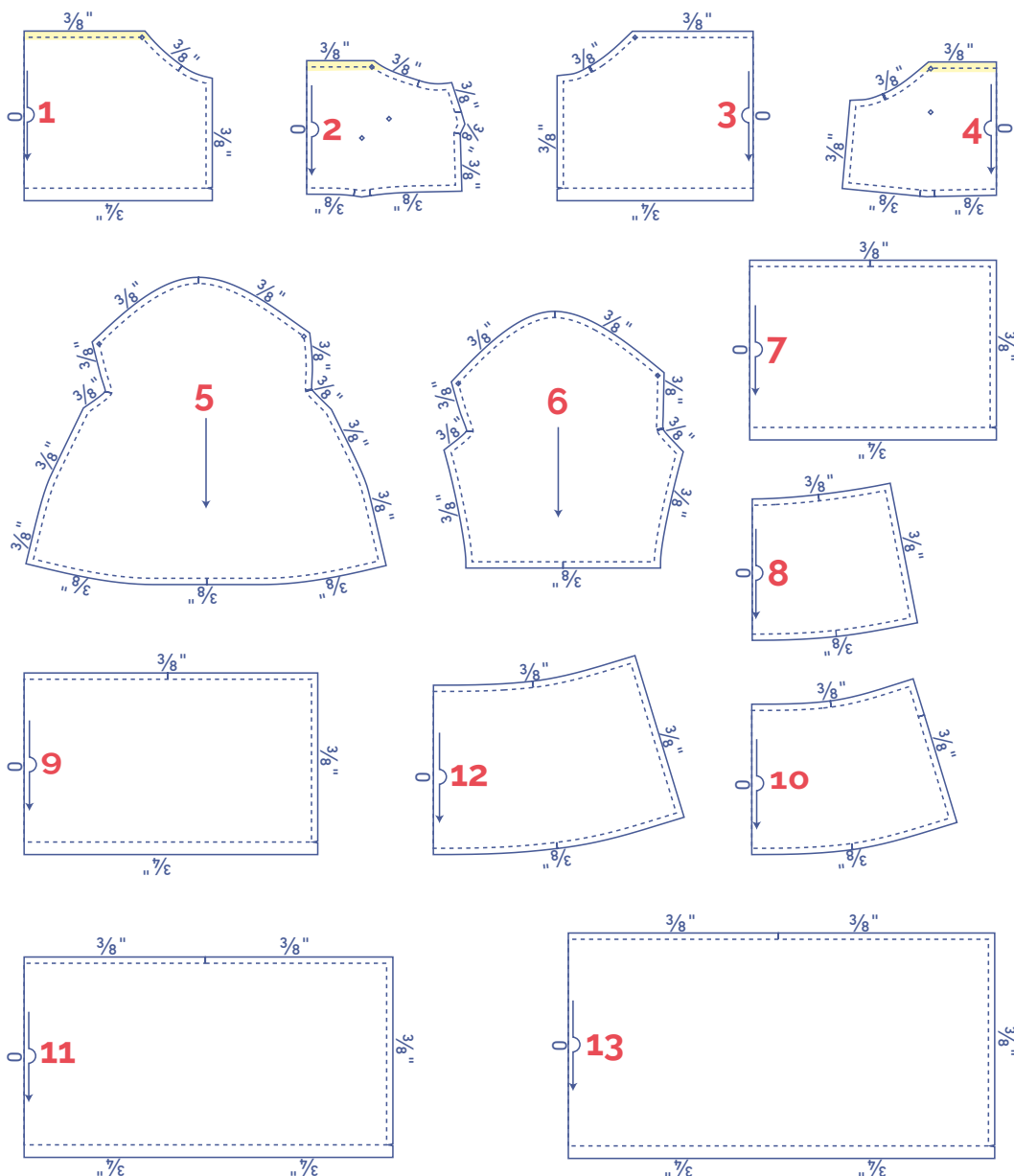
Reinforce the neckline of pattern sections 2 and 4 by ironing stay tape along the wrong side to prevent stretching.



	material type
	fabric
	iron-on interfacing

fabric layout for solid fabrics
fabric width 43"

XS - S

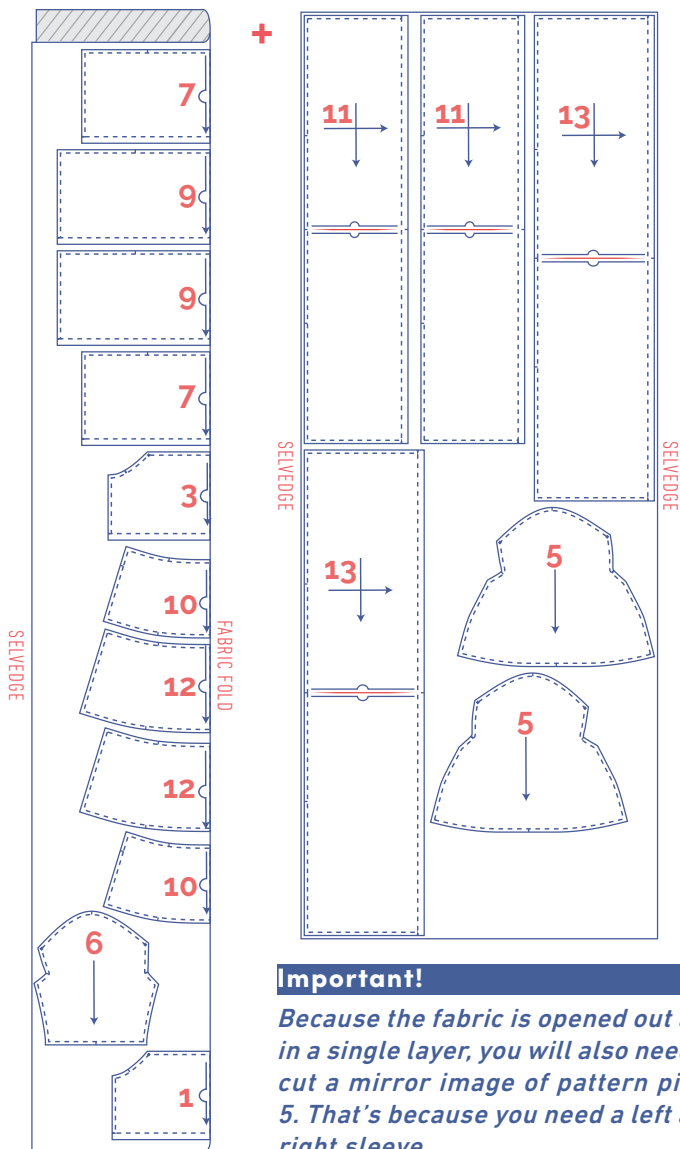

Important!

Because the fabric is opened out and in a single layer, you will also need to cut a mirror image of pattern piece 5. That's because you need a left and right sleeve.

Pattern pieces 11 and 13 have been rotated at a 90° angle to fit the fabric width. Be aware of this if you are working with patterned or napped fabric.

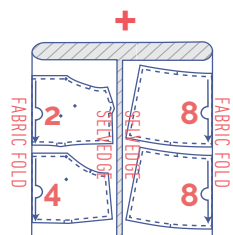

M - L

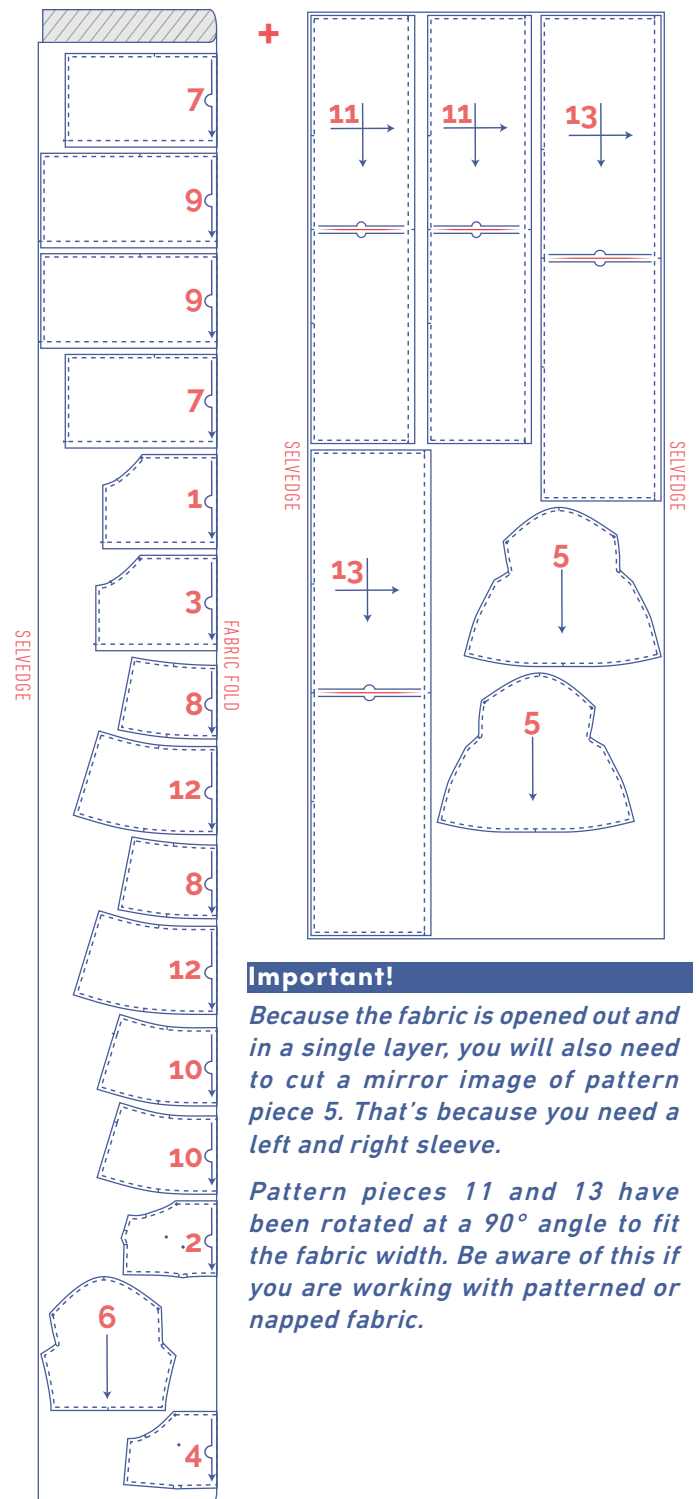

Important!

Because the fabric is opened out and in a single layer, you will also need to cut a mirror image of pattern piece 5. That's because you need a left and right sleeve.

Pattern pieces 11 and 13 have been rotated at a 90° angle to fit the fabric width. Be aware of this if you are working with patterned or napped fabric.

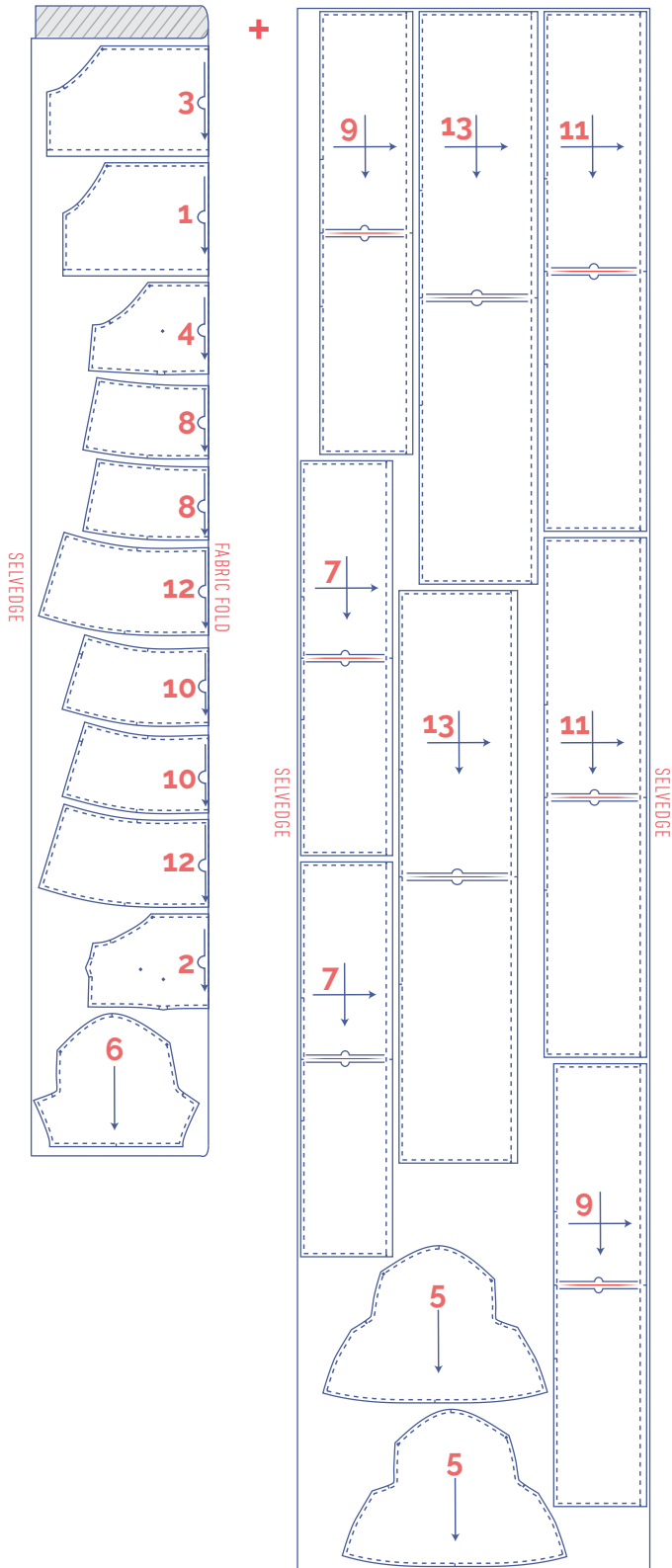



Important!

Because the fabric is opened out and in a single layer, you will also need to cut a mirror image of pattern piece 5. That's because you need a left and right sleeve.

Pattern pieces 7, 9, 11 and 13 have been rotated at a 90° angle to fit the fabric width. Be aware of this if you are working with patterned or napped fabric.

marking pattern pieces

	notch the paper pattern and fabric at the following points
	single notch
	double notch
∨	V notch/fabric fold
	mark with a marking thread
	centre point

fabric layout for solid fabrics fabric width 55"

XS - S

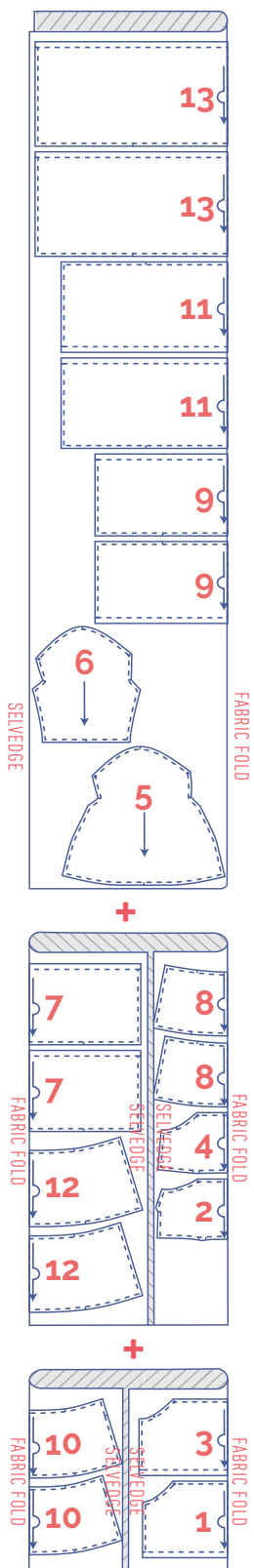

M - L

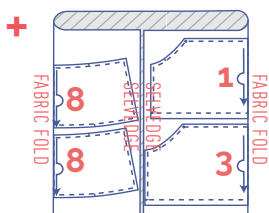
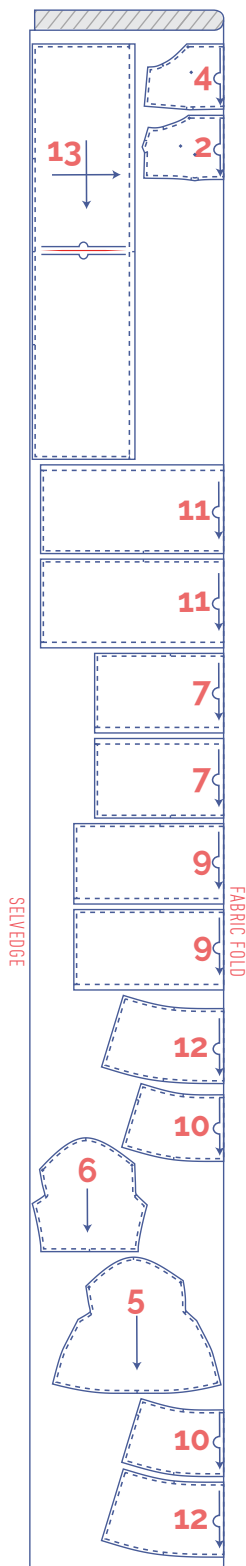

XL - XXL

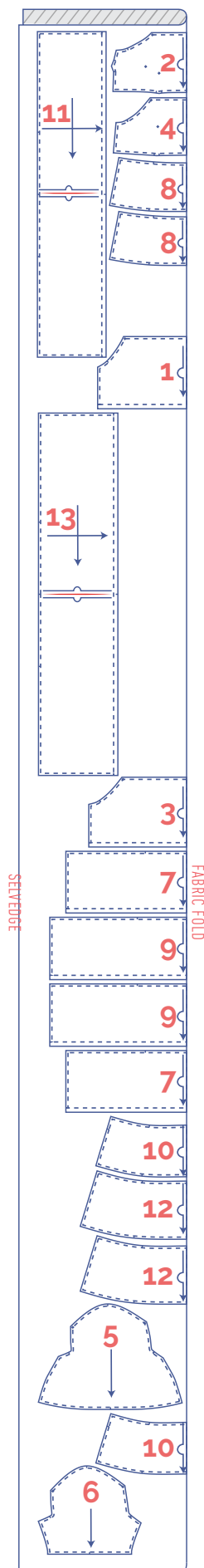

Important!

Pattern pieces 11 and 13 have been rotated at a 90° angle to fit the fabric width. Be aware of this if you are working with patterned or napped fabric.

Important!

Pattern piece 13 has been rotated at a 90° angle to fit the fabric width. Be aware of this if you are working with patterned or napped fabric.

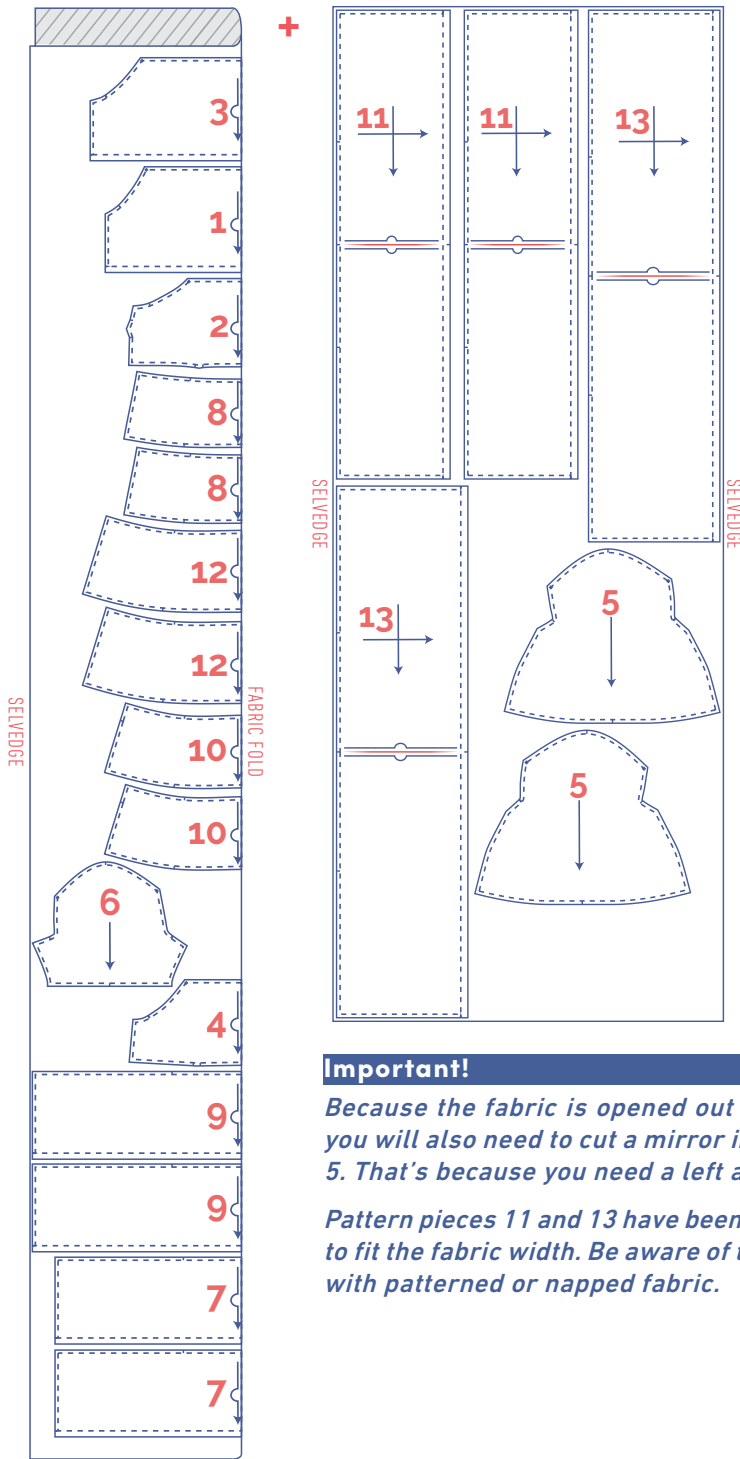

Important!

Because the fabric is opened out and in a single layer, you will also need to cut a mirror image of pattern piece 5. That's because you need a left and right sleeve.

Pattern pieces 11 and 13 have been rotated at a 90° angle to fit the fabric width. Be aware of this if you are working with patterned or napped fabric.

marking pattern pieces

	notch the paper pattern and fabric at the following points		mark with a marking thread
	single notch		centre point
	double notch		
V	V notch/fabric fold		

sewing instructions



The method used to finish the seams depends on the fabric used. The pieces are always sewn together with the right sides of the fabric facing, unless stated otherwise.



F front

B back

CF centre front

CB centre back

 right side

 wrong side

 iron-on interfacing

 elastic

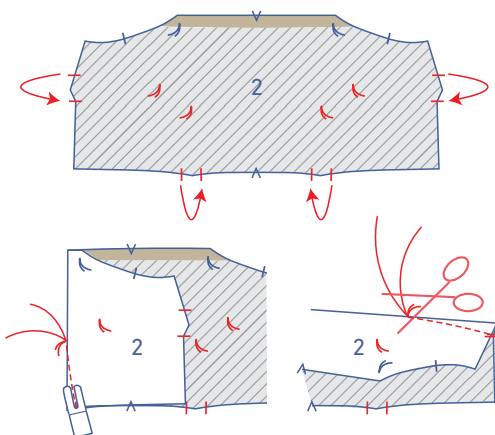
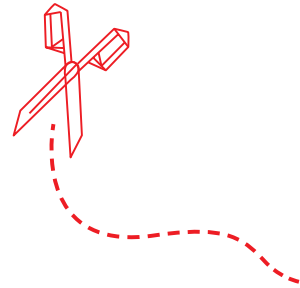

1

Match the notches in the side and waist seam of the lining F (2) with the wrong sides of the fabric together. Sew the dart in a slightly curved line towards the marking thread. Sew up to and just past the marking thread, so that you've sewn past the fabric. Snip the threads and tie a knot.

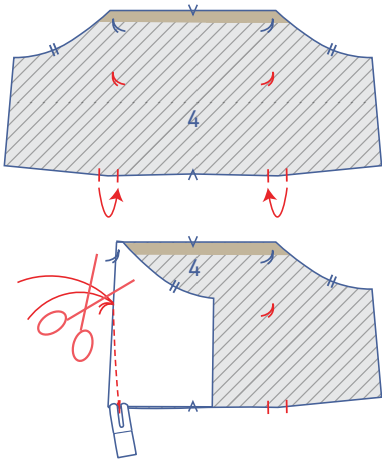

Match the notches in the waist seam of the lining B (4) with the wrong sides of the fabric together. Sew the dart in a slightly curved line towards the marking thread. Sew up to and just past the marking thread, so that you've sewn past the fabric. Snip the threads and tie a knot.

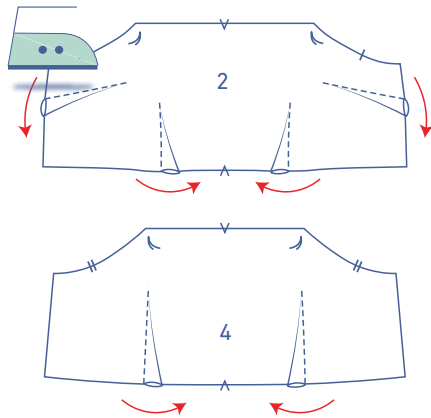

Flip the pieces so the right side is facing upwards. Press the darts as shown.

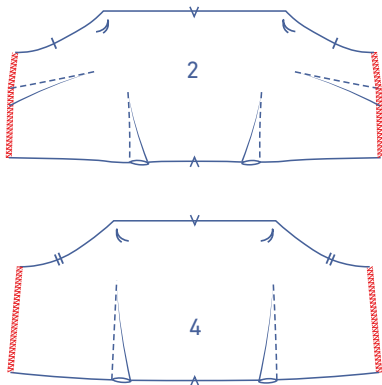

Finish the raw edges with overlock stitching where indicated.

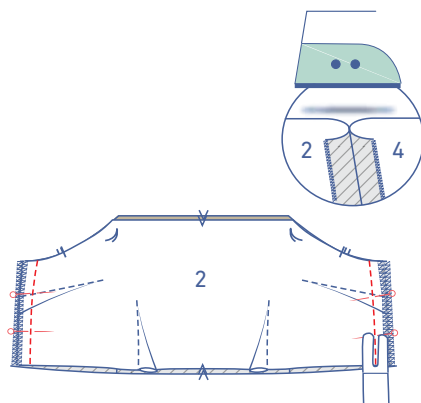

Pin and sew the side seams with the wrong sides of the fabric together. Press the seam allowance open.

Finish the raw edges of the inner sleeve (6) with overlock stitching where indicated.

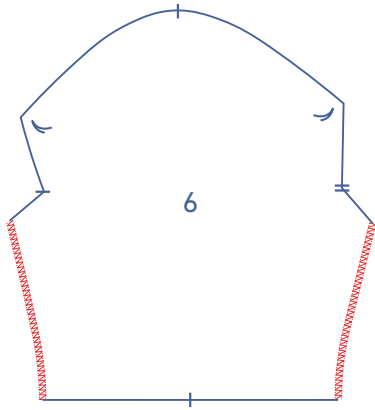

Pin and sew the underarm seam. Press the seam allowance open.

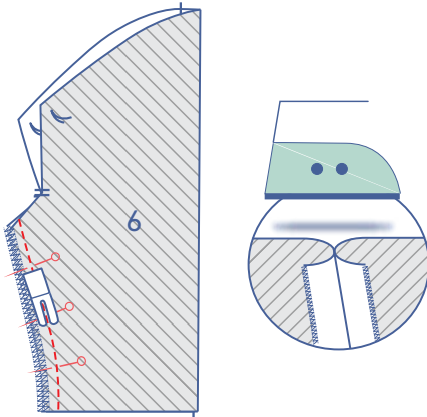

Pin the inner sleeve to the lining garment right sides together, matching marking threads and notches. Sew the inner sleeve into place from one marking thread to the other.

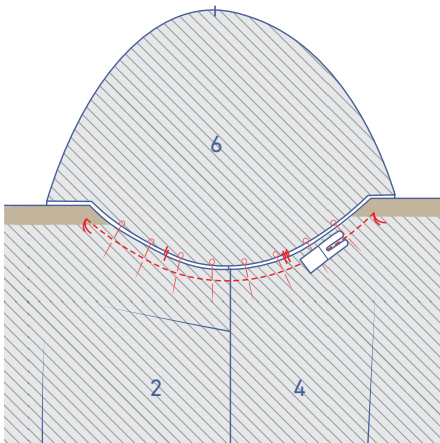

Finish the raw edges with overlock stitching. Press the seam allowance in the direction of the inner sleeve.

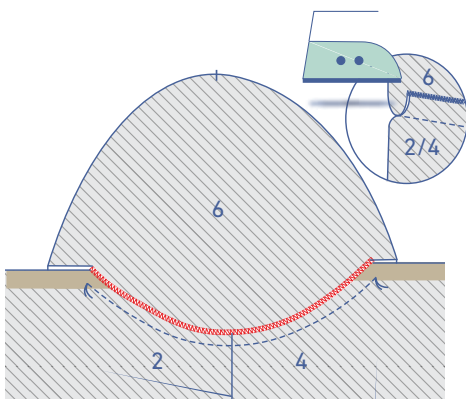

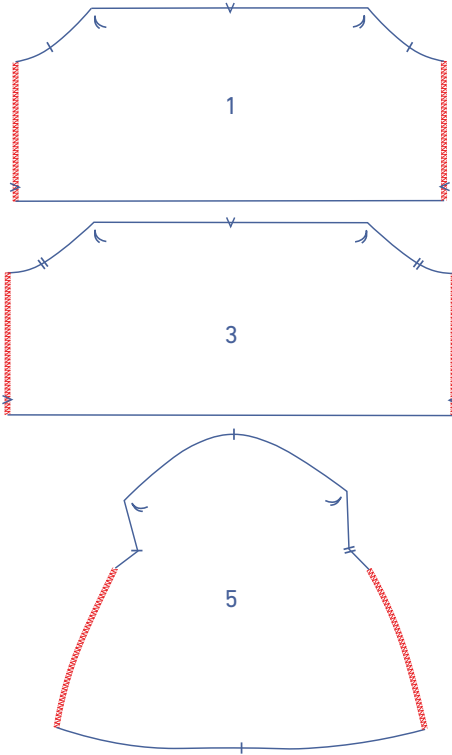

2

Finish the raw edges of the pieces F (1), B (3) and outer sleeve (5) with overlock stitching where indicated

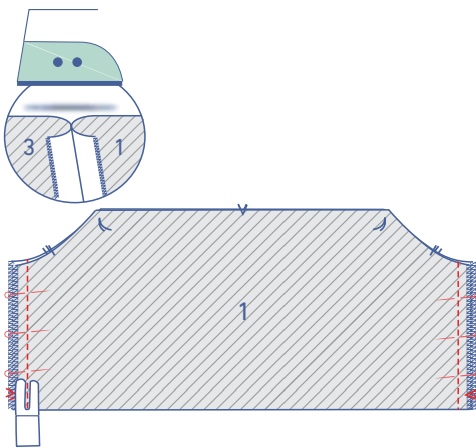

Pin and sew the side seams of the front and back. Press the seam allowances open.

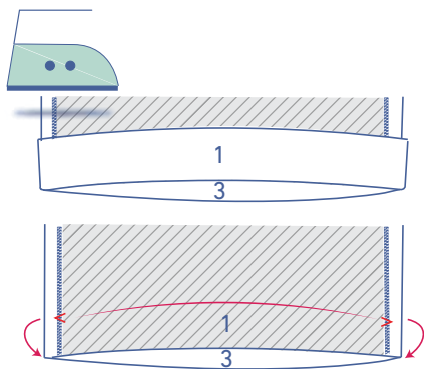

Fold the hem allowance towards the wrong side, press, and then open back out.

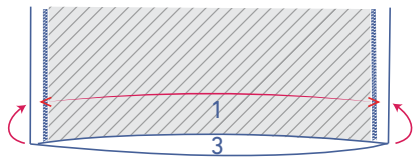

Match the raw edge to the pressed fold line and fold over again.

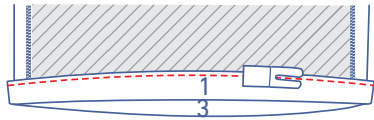
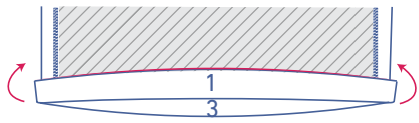

Edgestitch into place.

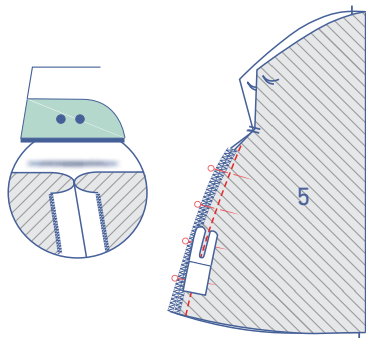

Pin and sew the underarm seam of the outer sleeve. Press the seam allowance open.

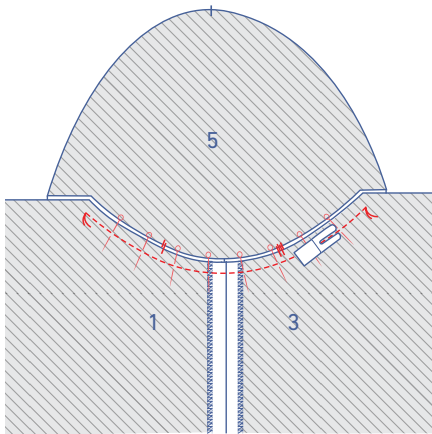

Pin the outer sleeve to F and B right sides together, matching marking threads and notches. Sew the outer sleeve into place from one marking thread to the other.

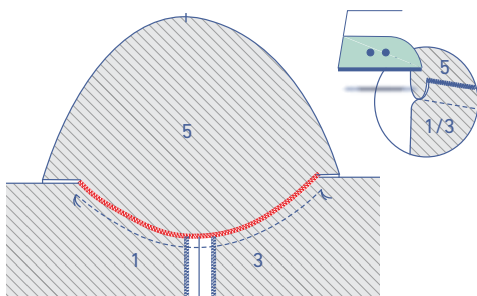

Finish the raw edges with overlock stitching. Press the seam allowance in the direction of the outer sleeve.

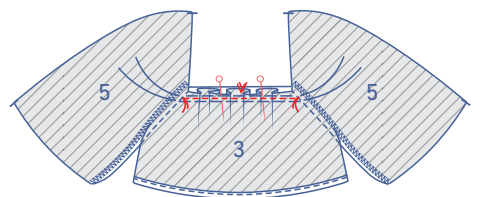
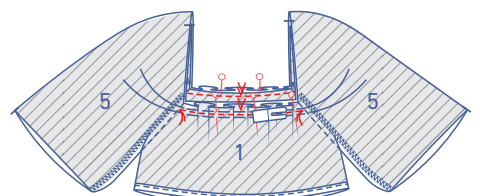
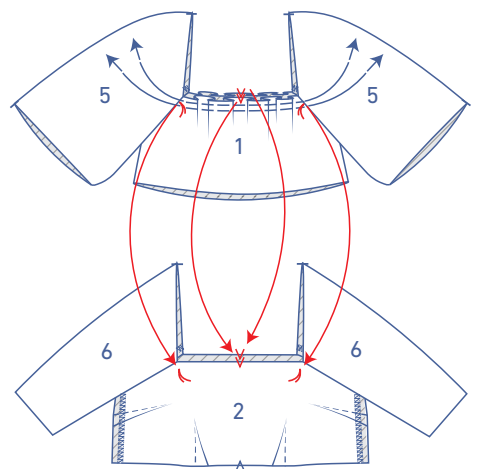
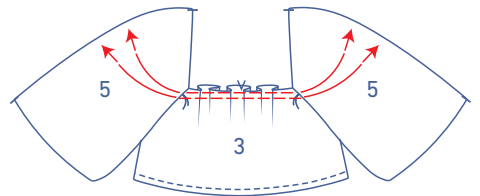
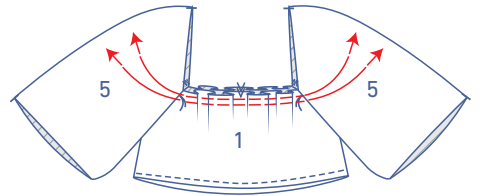
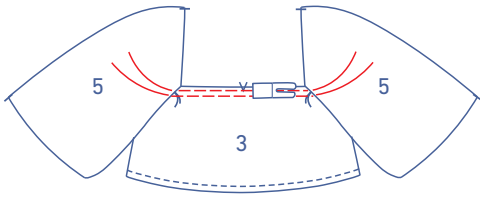
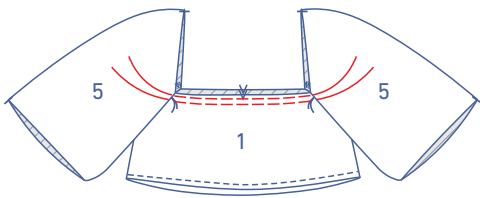

3

Sew 2 parallel lines of stitching at the top of F and B, using a long stitch length at a low thread tension. Leave a length of thread at the start and end of your stitching.

Then, gently tug the gathering threads to gather the fabric.

Turn the F and B piece inside out. Pin the lining to F and B, with the right sides together, while distributing the gathers between the marking threads until the markings match.

Sew each into place between the marking threads.

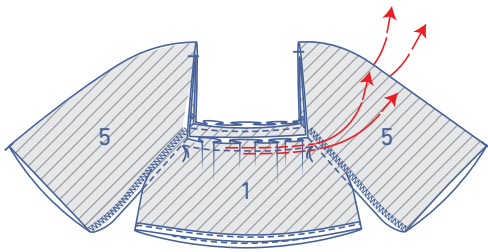

Remove the gathering threads.

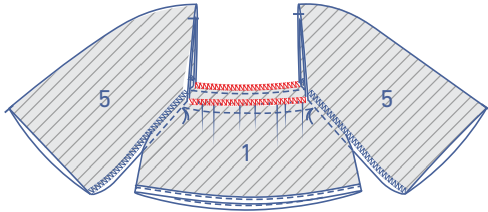

Finish the raw edges with overlock stitching.

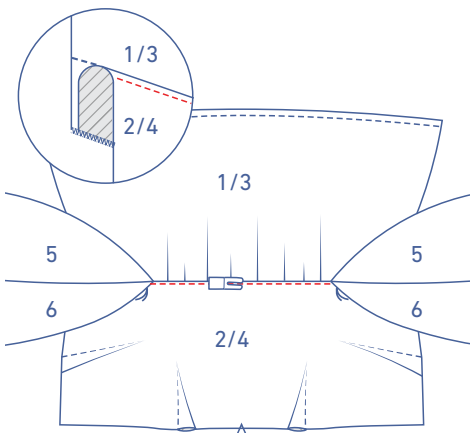

Fold the lining to one side and stitch it on to the seam allowance underneath, right next to the seam.

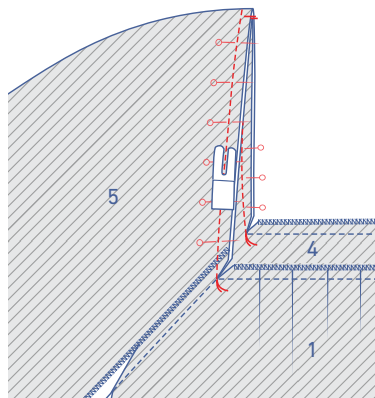

4

Pin and sew the top of the inner and outer sleeve between the marking threads, right sides together matching markings.

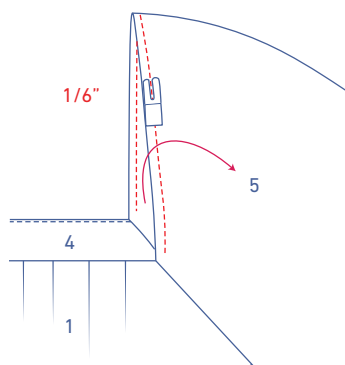

Turn the right way out. Sew 1/6" from the edge.

Thread the elastic through the tunnel.

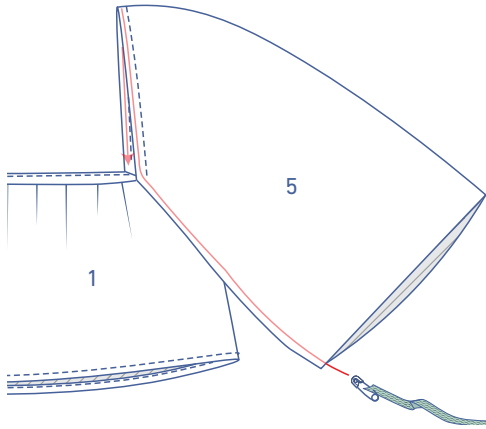

Sew the ends of the elastic into place at the seam.

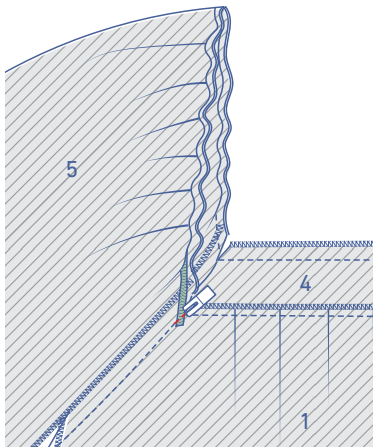

Sew two lines of parallel stitching at the bottom of the outer sleeve, using a long stitch length at a low thread tension. Leave a length of thread at the start and end of your stitching.

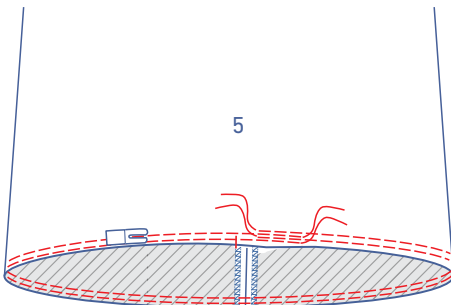

Then, gently tug the gathering threads to gather the fabric.

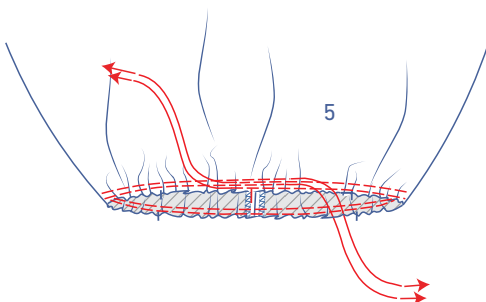

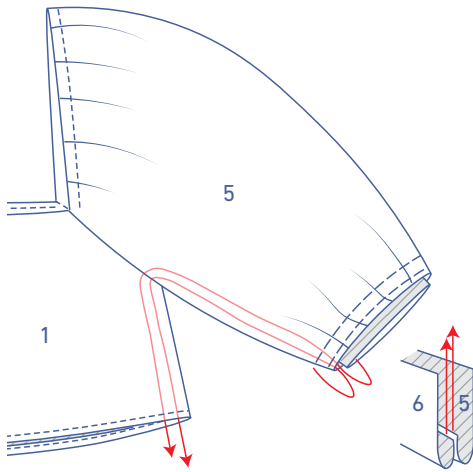

Slide the inner sleeve into the outer sleeve until it is correctly positioned. Now fold the seam allowance of the hems right sides together, hold them tight and pull them through in between F + B and lining F + B.

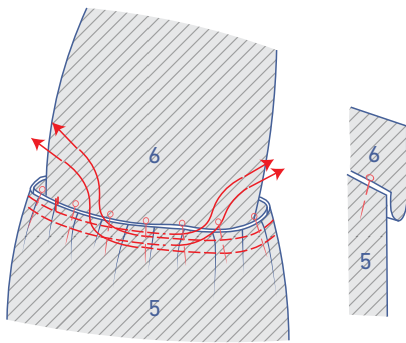

Line up the raw edges and pin into position, distributing the gathers until the markings match.

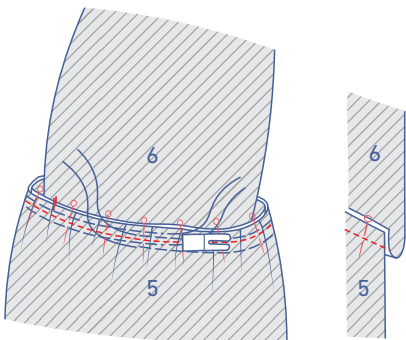

Sew into place.

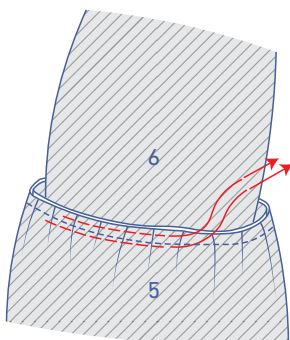

Remove the gathering threads.

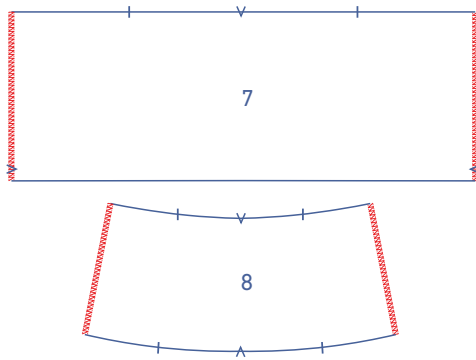

5

Finish the raw edges of ruffle 1 (7) and lining 1 (8) with overlock stitching where indicated.

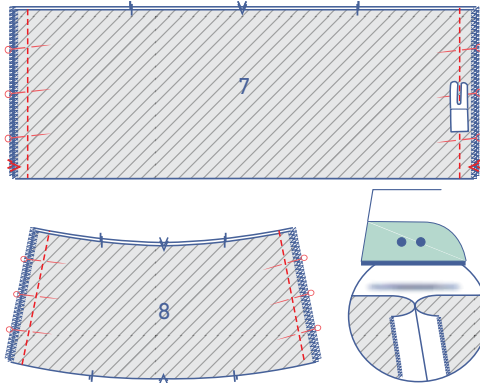

Pin and sew the side seams of both the ruffle and the lining. Press the seam allowances open.

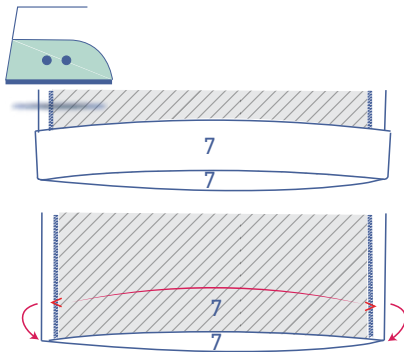

Fold the hem allowance on the ruffle towards the wrong side, press, and open back out.

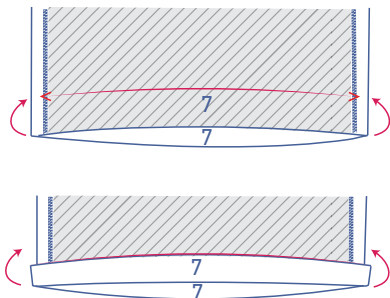

Match the raw edge to the pressed fold line and fold over again.

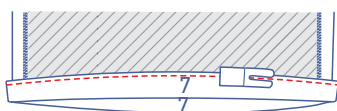

Edgestitch into place.

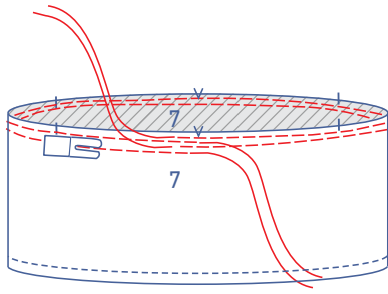

Use a long stitch at a low thread tension to sew the top of the ruffle with two parallel lines of stitching. Leave a length of thread at the start and end of your stitching.

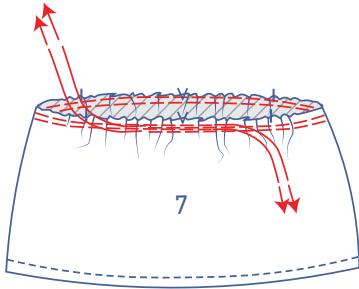

Then, gently tug the gathering threads to gather the fabric.

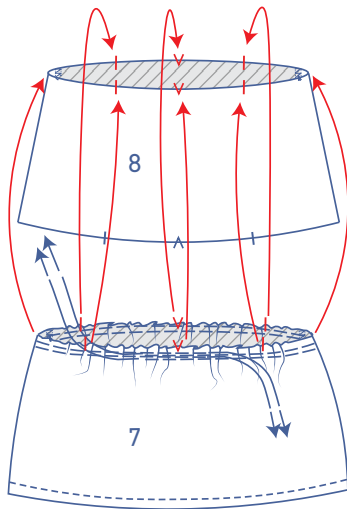

Slide the ruffle over the lining, wrong side of the ruffle facing the right side of the lining. Distribute gathers so the markings match.

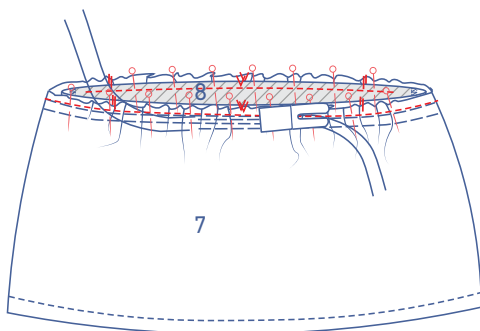

Sew into place at presser foot width from the edge.

Slide the ruffle/lining over the bottom of the F + B lining, right side of the ruffle facing the wrong side of the F + B lining. Pin and sew in place, matching markings.

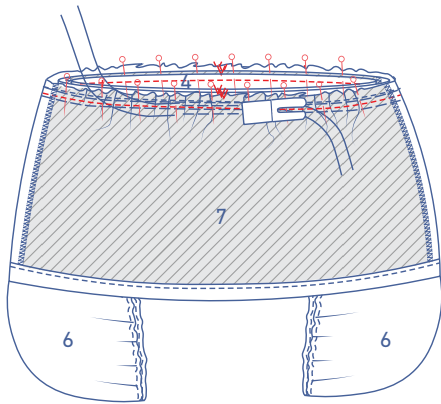
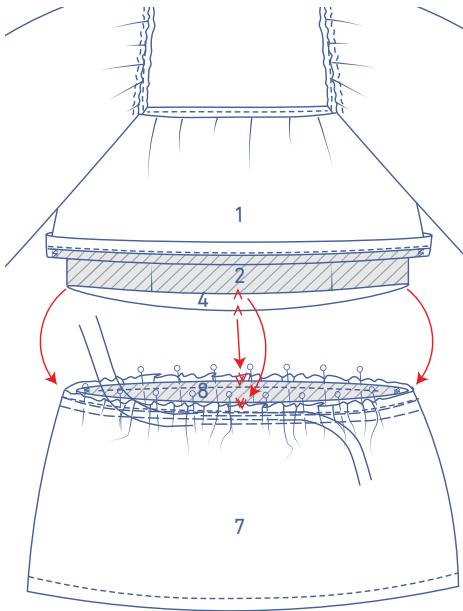

Remove the gathering threads.

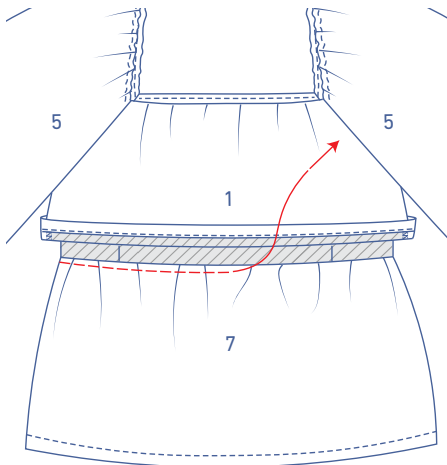

Finish the raw edges with overlock stitching.

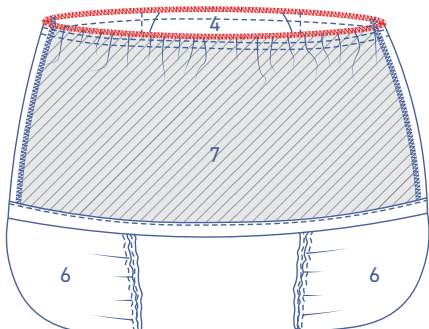

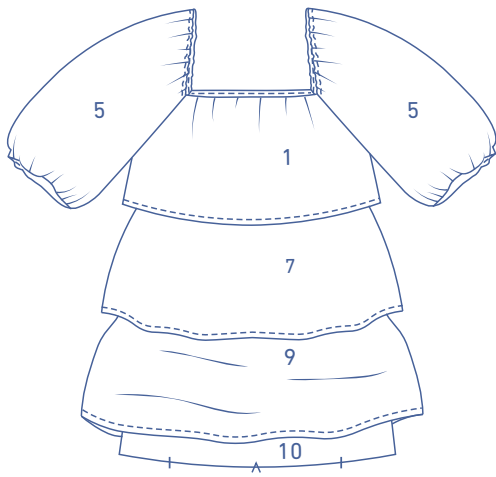

Repeat this step in order to sew the pieces ruffle 2 (9) and lining 2 (10) to the bottom of the right side of lining 1.

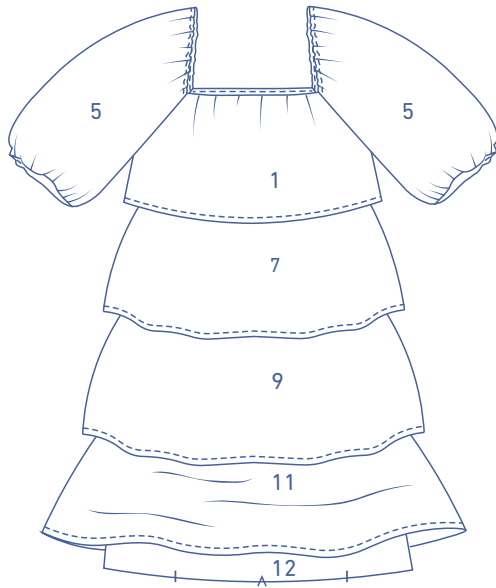

Repeat the step to sew ruffle 3 (11) and lining 3 (12) at the bottom of the right side of lining 2.



6

Finish the raw edges of ruffle 4 (13) with overlock stitching where indicated.



Pin and sew the side seams together. Press the seam allowances open.

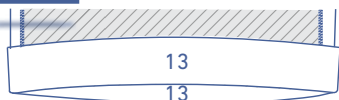
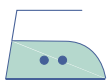
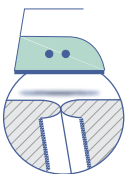

Fold the hem allowance towards the wrong side, press, and then open back out.

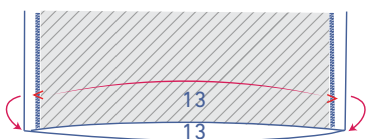

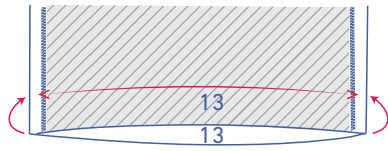

Fold the raw edge to the pressed fold line and fold over again.

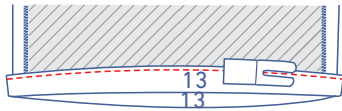
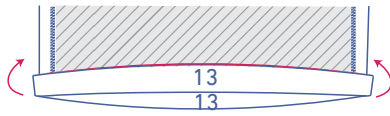

Edgestitch into place.

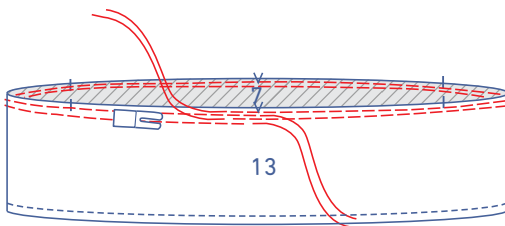

Use a long stitch at a low thread tension to sew the top of the ruffle with two parallel lines of stitching. Leave a length of thread at the start and end of your stitching.

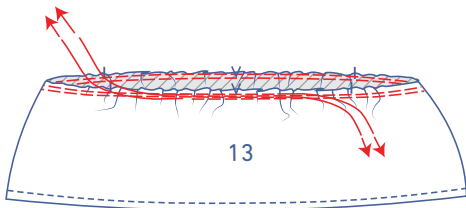

Then, gently tug the gathering threads to gather the fabric.

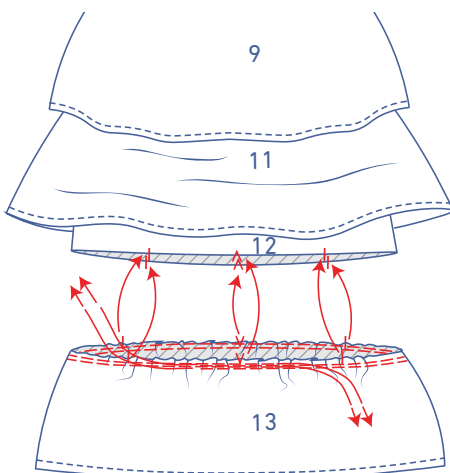

Pin the top of the ruffle to the bottom of lining 3, with the right sides together, distributing the gathers until the markings match.

Sew into place.

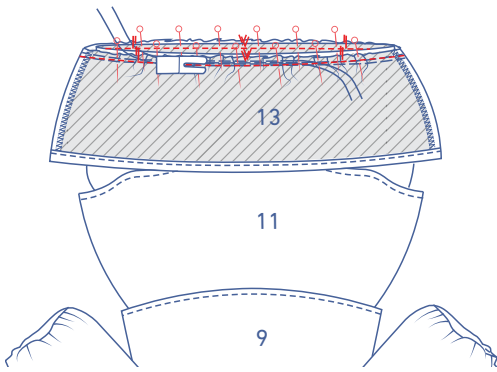

Remove the gathering threads.

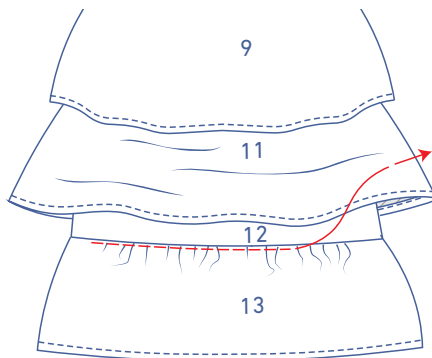

Finish the raw edges with overlock stitching.

