



Vivienne by Fibre ood

Vivienne by Fibre ood



Version without welt pocket



Version with welt pocket



XS - XXXL

Hot, hot, hot this season! Classy, super-feminine and wonderful worn with a T-shirt or on her own. Vivienne is lined, has a loose fit and has a side panel plus a front and back panel. Seam lines add an elegant touch.

Another must with this waistcoat: a row of buttons and welt pockets. Don't want the welt pockets? Then just leave them out, it immediately makes things easier and quicker...

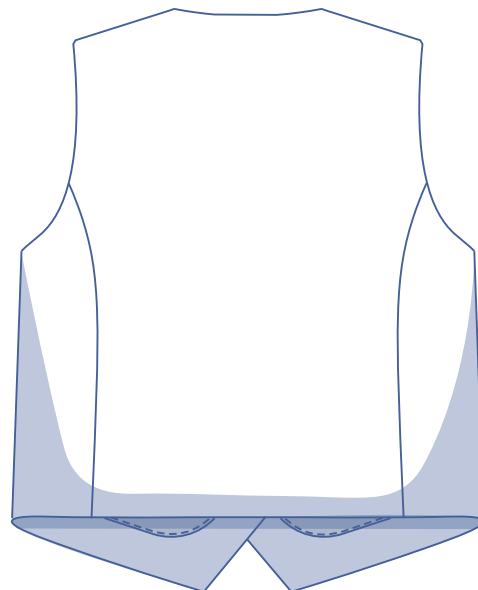
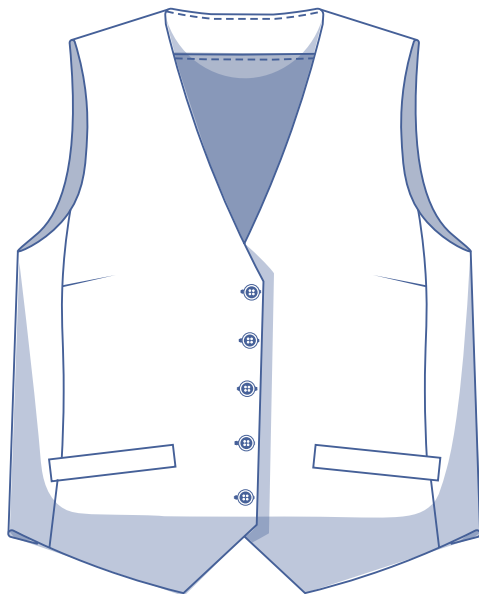

size chart (in cm)

size	XS		S		M		L		XL		XXL		XXXL		
	4	6	8	10	12	14	16	18	20	22	24	26	28	30	32
body height	160	164	166	167	168	169	170	171	172	172	172	172	172	172	172
B (bust)	76	80	84	88	92	96	100	104	110	116	122	128	134	140	146

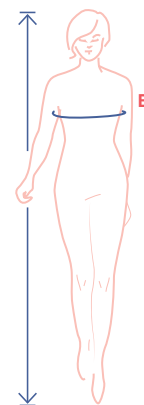

Choose your size based on the bust measurement. Pick the size that is the best match for your chest. Then, check the hem measurements in the table below to be sure there is sufficient room in the length.

pattern measurements (in cm)

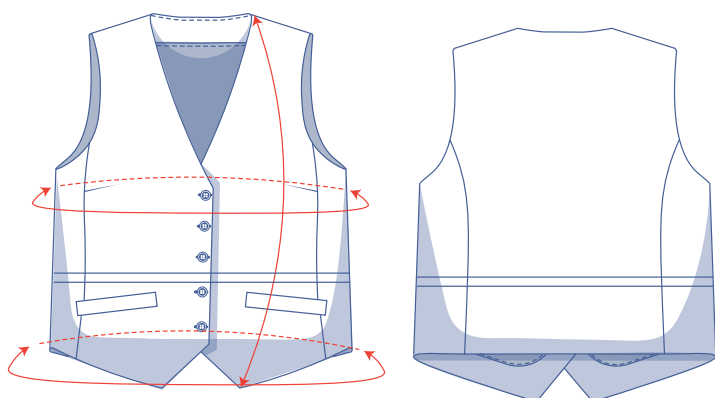

== shorten or lengthen the pattern here

This chart's measurements are the pattern measurements based on the fabric type and serve as a reference. Ease has been added to the width measurements (in addition to the exact body measurements) for a more comfortable fit. Vivienne is designed to have a relaxed cut.

size	XS	S	M	L	XL	XXL	XXXL
length	55.25	57.25	59.5	61.5	68.25	71	73.75
bust	85.25	93.25	101.25	109.25	119.25	131.25	143.25
hem circumference	92	100	108	116	126	138	150

Compare the stated lengths to the measured or desired lengths. Lengthen or shorten the waistcoat by cutting the pattern pieces at the indicated double lines. Then either increase the distance between the cut pieces by the desired amount (to lengthen) or overlap the pieces (to shorten). Make sure that the CF and CB lines and the side seams are always straight.

IMPORTANT

Adjust the amount of fabric to be used based on these alterations.

notions



- Thread
- Iron-on interfacing: max. 80 cm
- Seam tape: max. 75 cm
- Buttons (Ø 1.2 - 1.5 cm): 5
- Lining: see table
- Fabric: see table

lining fabric use		XS	S	M	L	XL	XXL	XXXL
fabric width 110 cm	cm	55	65	80	85	100	105	105
fabric width 140 cm	cm	55	55	60	60	70	90	105

The corresponding fabric layout can be found on page 6 of these sewing instructions.

fabric use		XS	S	M	L	XL	XXL	XXXL
fabric width 110 cm	cm	110	110	115	140	155	160	165
fabric width 140 cm	cm	80	100	100	105	125	130	135

The corresponding fabric layout can be found on page 6 of these sewing instructions.

fabric advice



Vivienne is best in a stiffer fabric, such as twill cotton, denim, fine corduroy, medium to heavy weight linen or gabardine. Light and supple fabrics are less suitable for this waistcoat.

HAPPINESS
is a
FULL BOBBIN

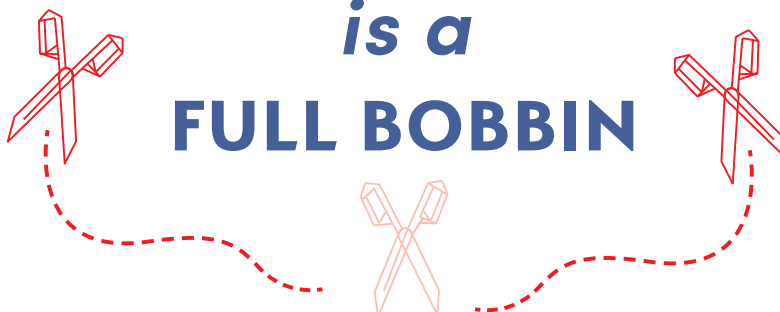

pattern pieces & seam allowances (in cm)





To sew the garment as described in the instructions, draw the illustrated seam allowances around the paper pattern pieces before cutting them out. If you are using a PDF pattern, the pattern can be printed with or without seam allowance. To find out more, watch the [video](#).

1. front: 2x
2. back: 1x on the fabric fold
3. side piece: 2x
4. pocket welt with inner pocket bag: 2x
5. outer pocket bag: 2x
6. facing F: 2x
7. facing B: 1x on the fabric fold
8. facing B+SP: 1x on the fabric fold
9. lining F: 2x
10. lining B: 1x on fabric fold
11. lining SP: 2x

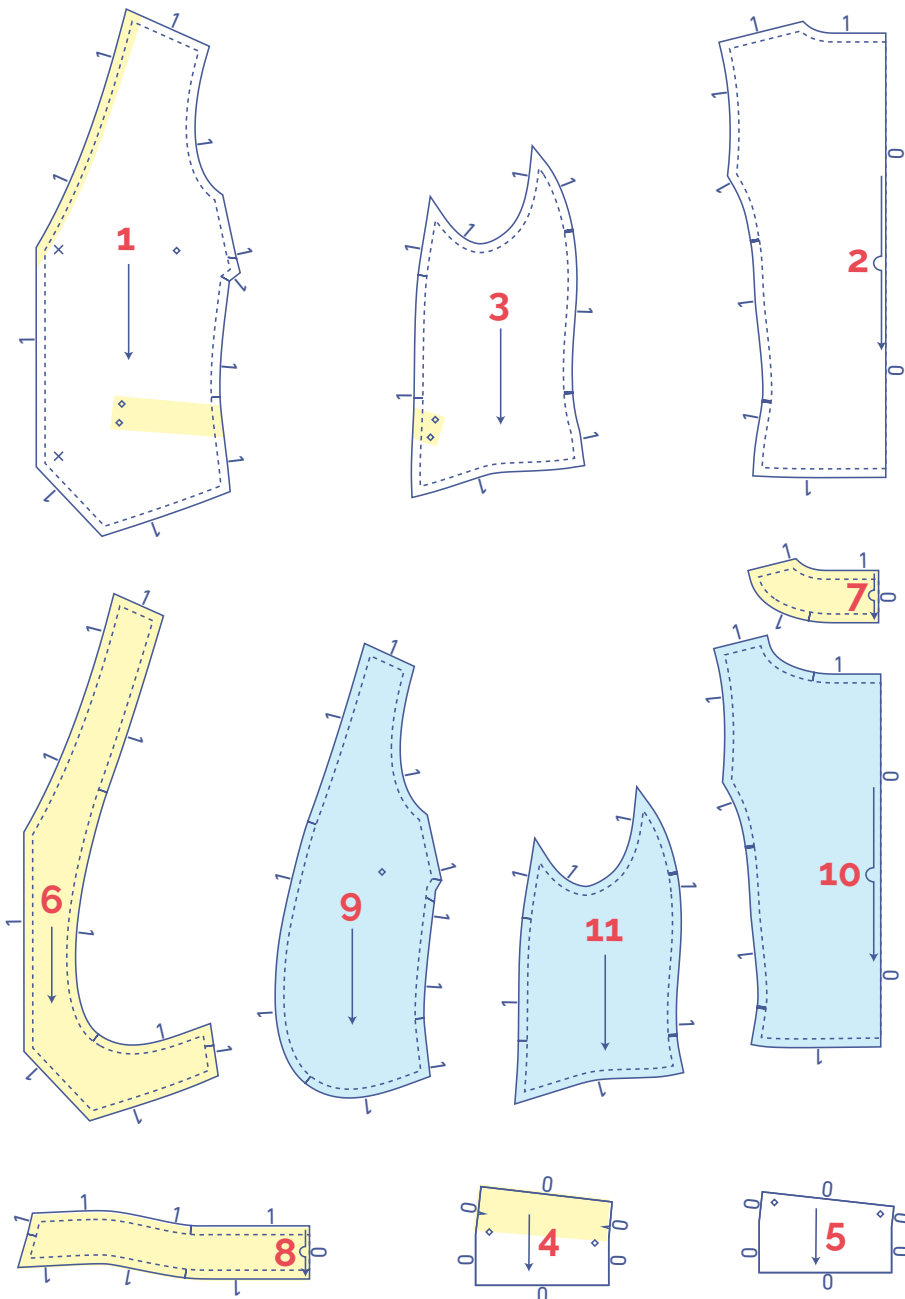
Tip!

Reinforce the neckline of pattern section 1 by ironing seam tape along the reverse side to prevent stretching.



 material type
 fabric
 iron-on interfacing
 lining

fabric layout for solid fabrics

fabric width 110 cm

XS - M

L - XXXL

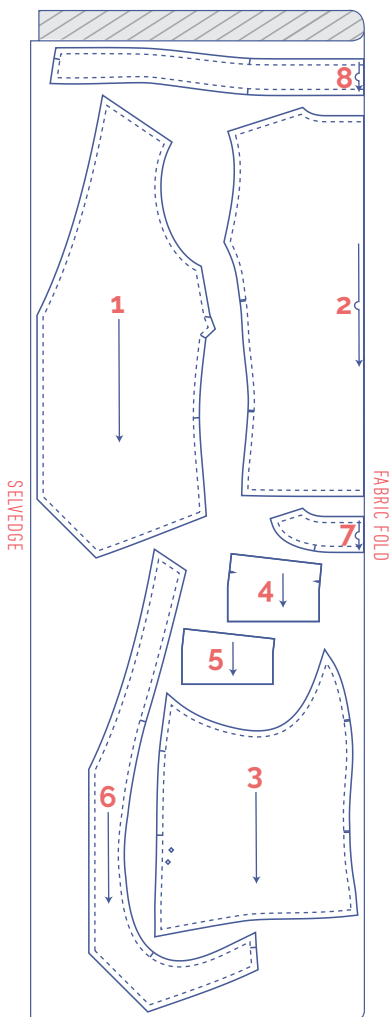
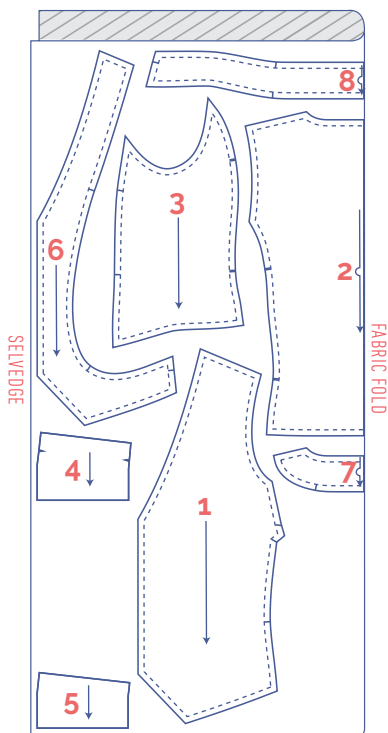

marking pattern pieces

	notch the paper pattern and fabric at the following points
	single notch
	double notch
V	V notch/fabric fold

	mark with a marking thread
	centre point
	snap fastener

fabric layout for a lining width of 110 cm

XS - L

XL - XXXL

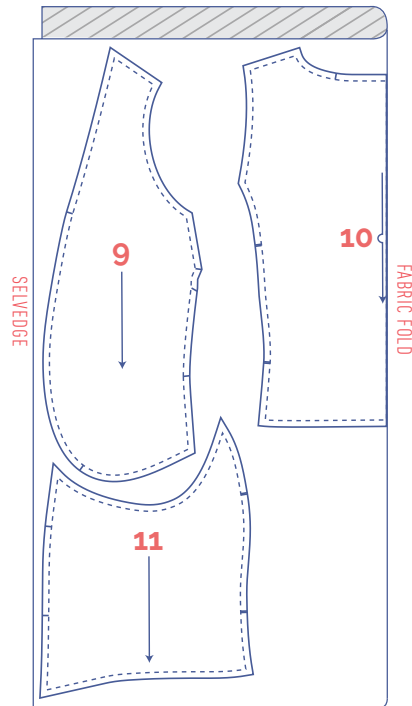
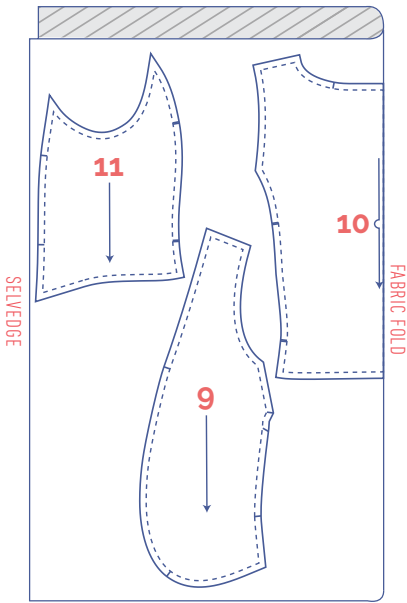

marking pattern pieces



notch the paper pattern and fabric at the following points

| single notch

|| double notch

fabric layout for solid fabrics
fabric width 140 cm

XS

S - L

XL - XXXL

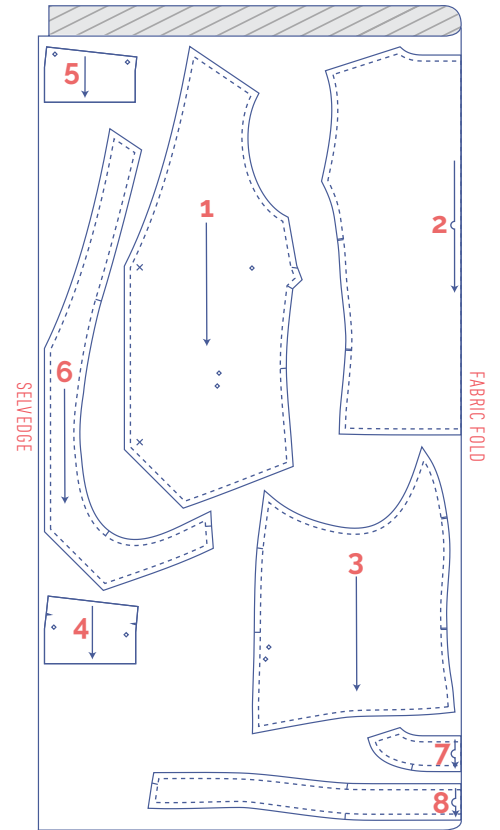
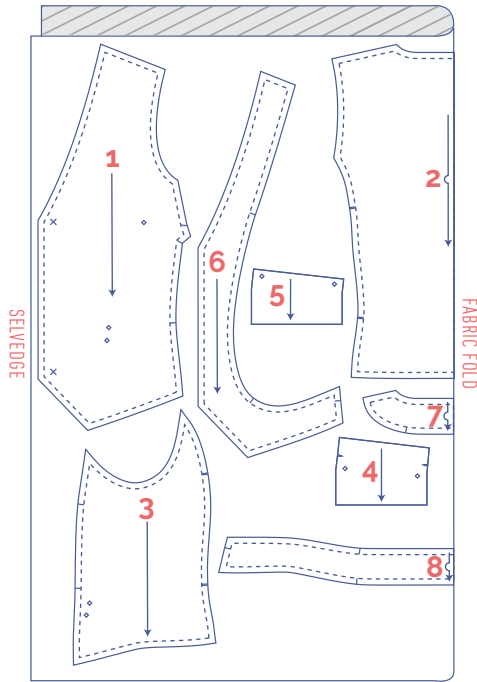
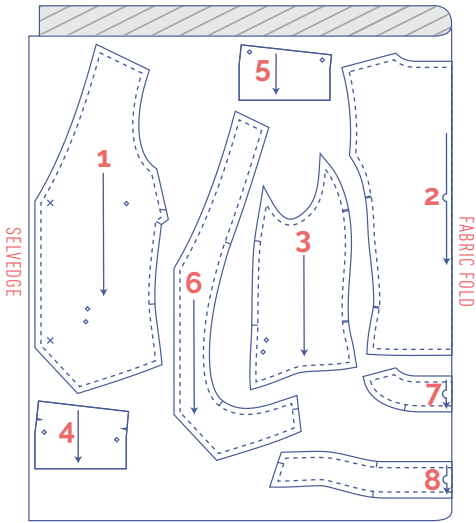





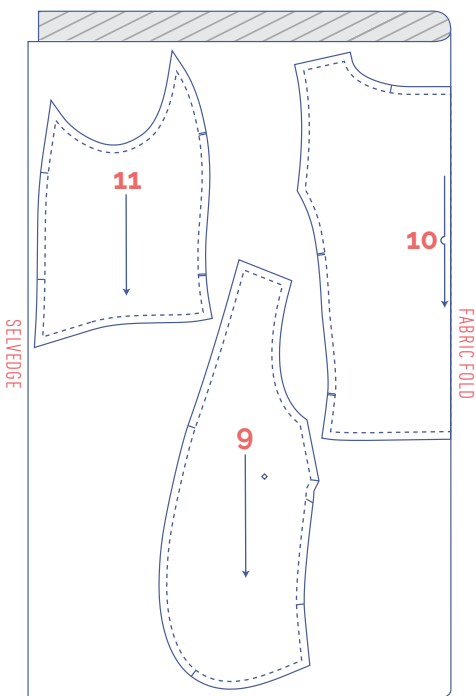

fabric layout for a
lining width of 140 cm

XS - XXXL



marking pattern pieces

	notch the paper pattern and fabric at the following points
	single notch
	double notch
	V notch/fabric fold
	mark with a marking thread
	centre point
	snap/button

sewing instructions



The method used to finish the seams depends on the fabric used. The pieces are always sewn together with the right sides of the fabric facing, unless stated otherwise.



F front

B back

SP side piece

CF centre front

CB centre back

RF right front 

LF left front 

 right side

 wrong side

 right side lining

 wrong side lining

 iron-on interfacing

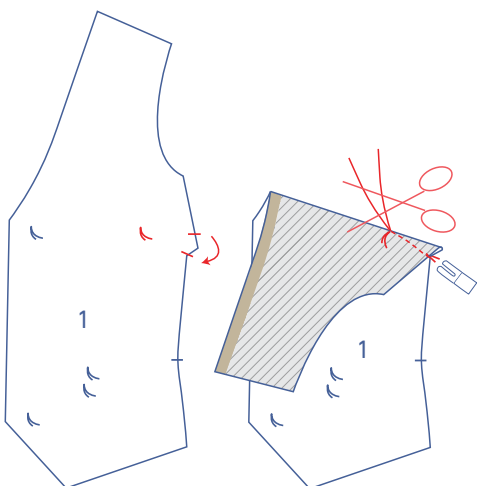
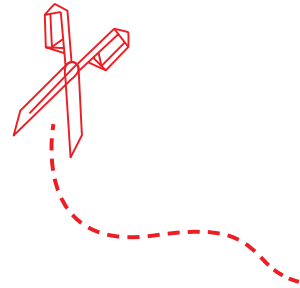

1

Fold together the notches marked on the side of F (1) with the right sides of the fabric facing. Sew the dart in a slightly curved line towards the marking thread. Sew up to and just past the marking thread, so that you've sewn past the fabric. Snip the threads and tie a knot.

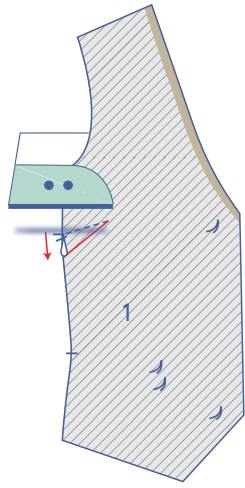

Turn over so that the wrong side is facing up. Press the dart down.

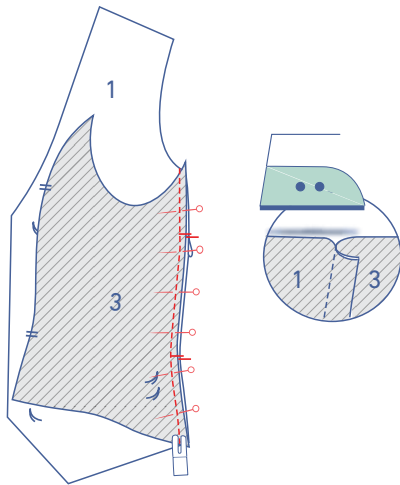

Pin and stitch the side with the single notches of the SP (3) to F. Press the seam allowance towards the SP.

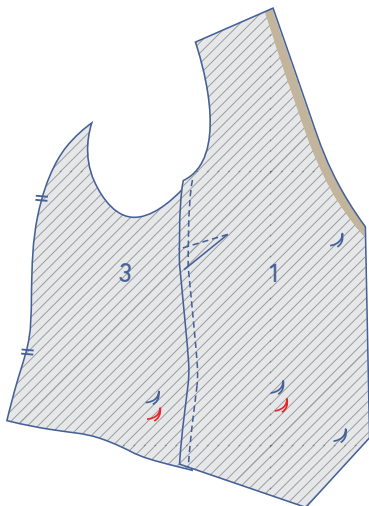

2

Use tailor's chalk to draw straight lines on the reverse side between the bottom corners of the pocket opening on F + SP (indicated by marking thread).

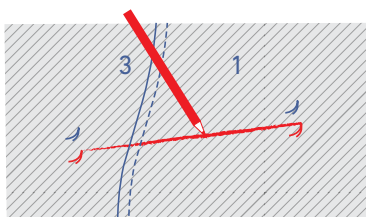

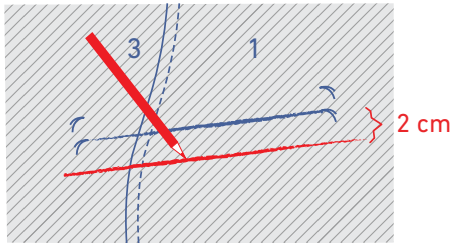

Now, draw a line below 2 cm parallel with the first.

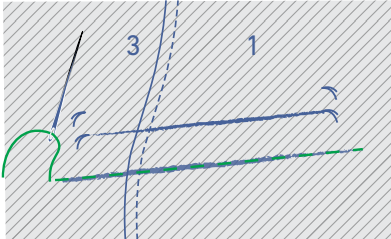

Use a brightly coloured thread to baste along this chalk line, so that the guidelines are visible along the right side of F + SP.

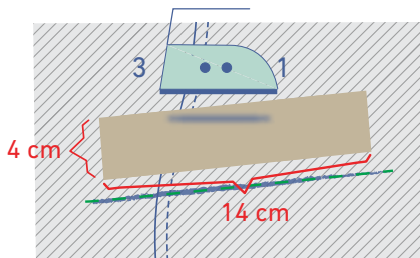

Iron a strip (4 x 14 cm) of iron-on interfacing in the indicated place.

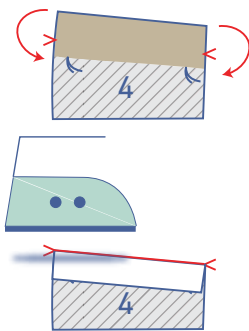

Press the pocket welt with inner pocket bag (4) towards the reverse side at the V notches with the wrong sides together.

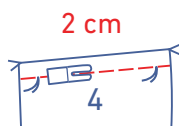

Place a line of basting stitches (long stitch length) 2 cm parallel to the fold line running the full length of the pocket welt.

Place the fold line of the pocket welt against the bright coloured guideline as shown, matching marking threads.

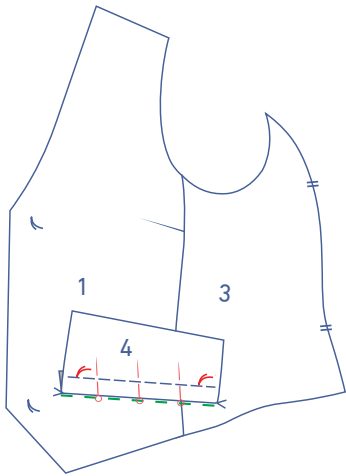

Sew along the basted helpline that you made earlier, starting and stopping exactly along at the marking threads.

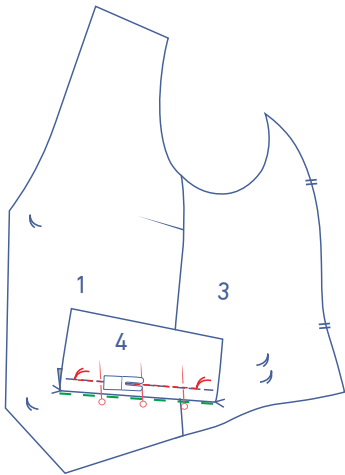

Press 1 cm of the outer pocket bag (5) over to the wrong side to create a fold line. Open back out.

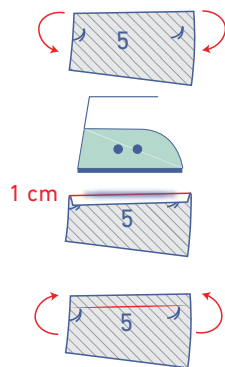

Fold the pocket welt with inner pocket bag over. Pin the outer pocket bag to F + SP, matching the upper marking threads.

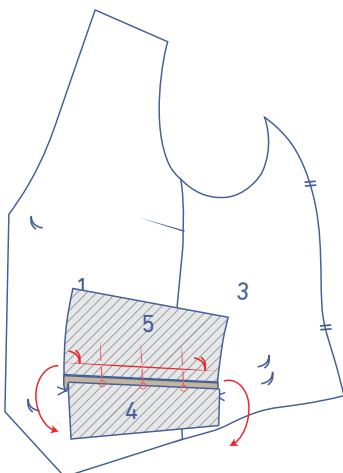

Sew directly over the fold line between marking threads.

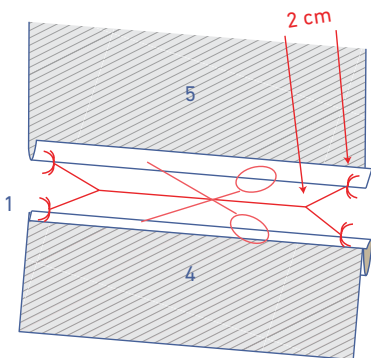
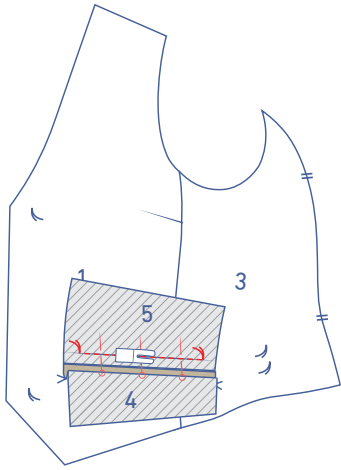

Fold both pocket pieces over and snip into F + SP between the 2 rows of stitching, stopping 2 cm away from the marking threads at each end. At both ends of the centre line, snip horizontally to the tip of each corner. Make sure that you only snip through F + SP and not into the pocket pieces.

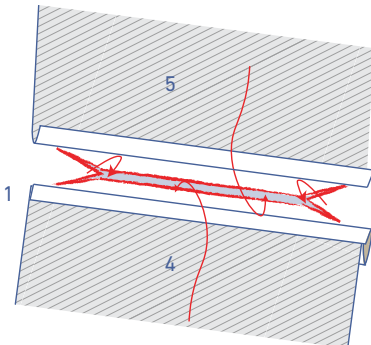

Push the pocket pieces through the opening to the wrong side. Fold the cut triangles (from the diagonal cuts) on either side of the pocket opening to the wrong side as well.

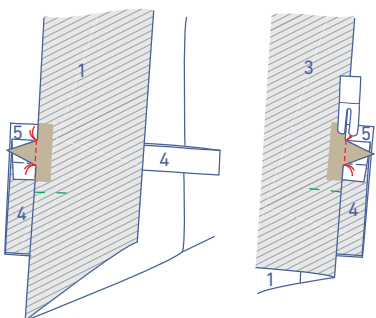

Lay both pocket pieces nice and flat, fold F + SP over and sew the triangles to the pocket pieces, working from corner to corner along both sides. Make sure that the right side of the welt has neat right angles.

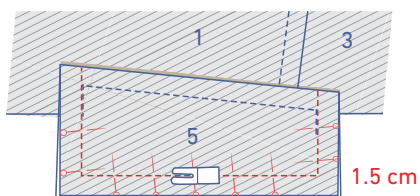

Turn over your work and sew the contours of the pocket pieces together with a 1.5 cm seam allowance.

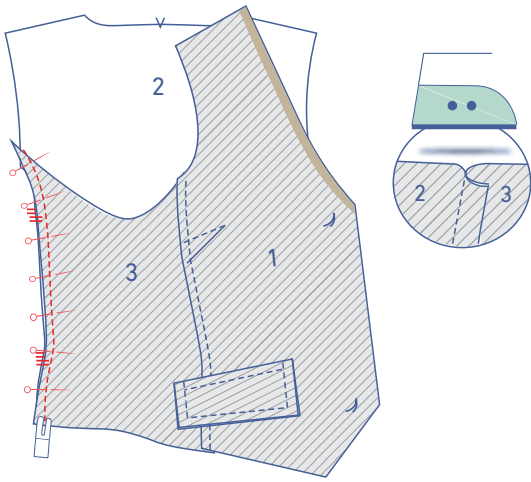

3

Pin and stitch the SP with the double notches to B (2). Press the seam allowance towards the SP.

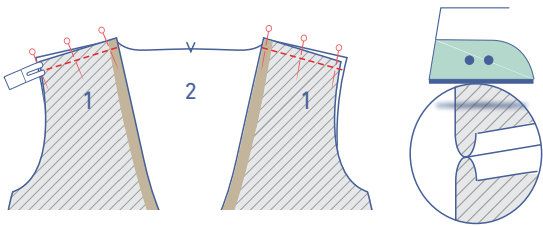

Pin and sew the shoulder seams together. Press the seam allowances open.

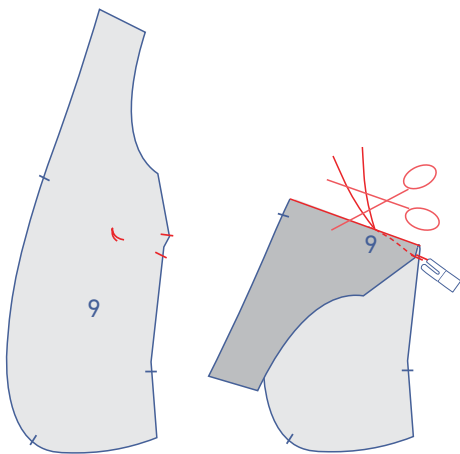

4

Fold together the notches marked on the side of lining F (9) with the right sides of the fabric facing. Sew the dart in a slightly curved line towards the marking thread. Sew up to and just past the marking thread, so that you've sewn past the fabric. Snip the threads and tie a knot.

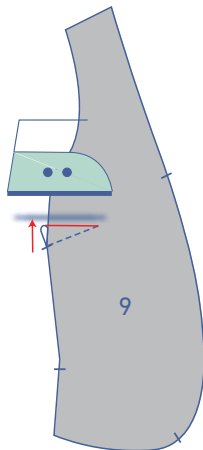

Turn over so that the wrong side is facing up. Press the dart upwards.

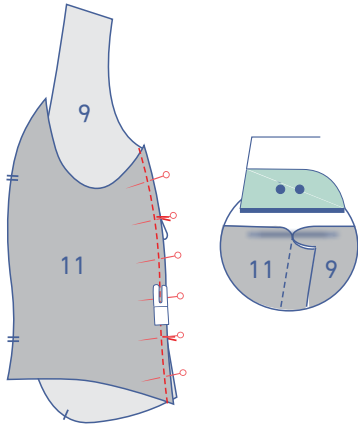

Pin and stitch the side of the lining SP (11) with the single notches to the lining F. Press the seam allowance towards the lining F.

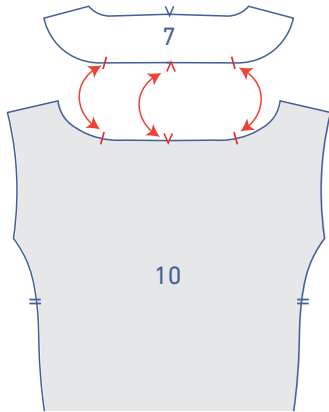

Pin the bottom of the facing B (7) to the top of the lining B (10) matching up the corresponding markings.

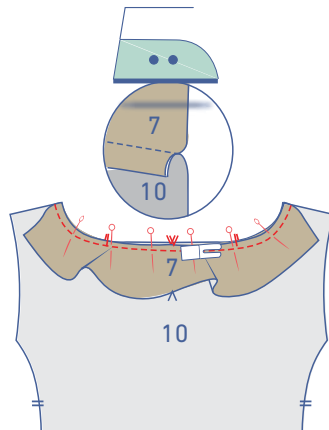

Sew into place. Press the seam allowance down towards the lining.

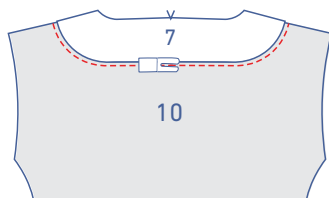

Stitch the lining right next to the seam.

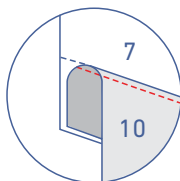

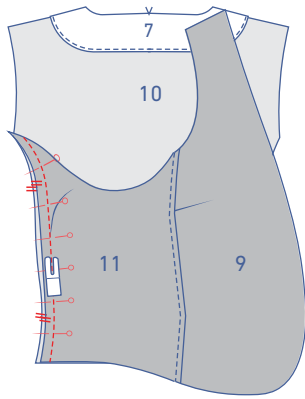

Pin and sew the side of the lining SP with the double notches to the lining B, however, leave an opening in one of the seams (so you can turn the waistcoat out afterwards). Press the seam allowance towards the lining B.

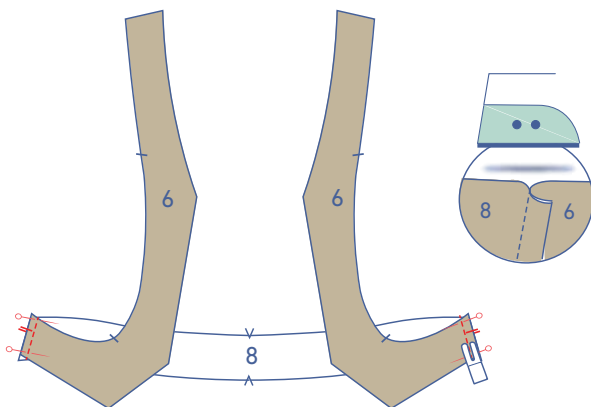
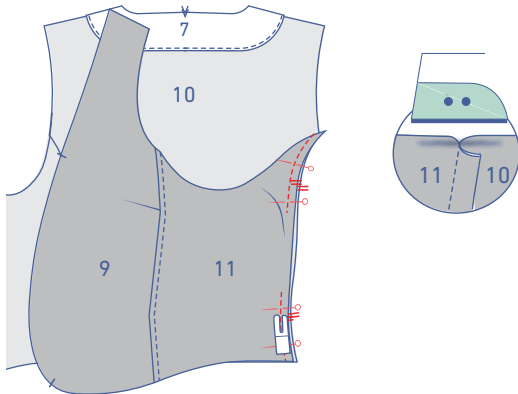

Pin and sew the facing F (6) to the facing B + SP (8) with the notches matching. Press the seam allowance towards the facing F.

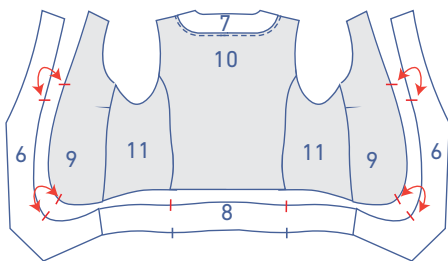

Pin and sew the facing to the lining right sides together, matching the markings. Press the seam allowance towards the lining.

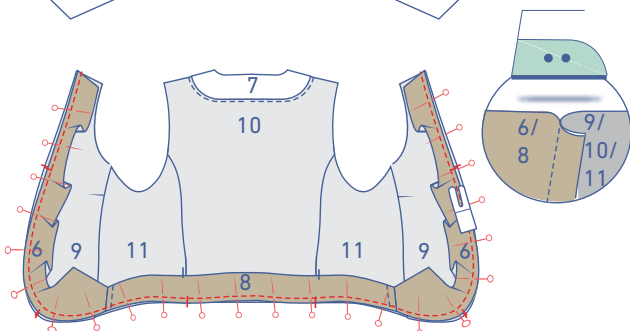

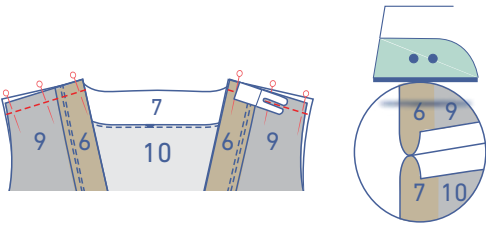
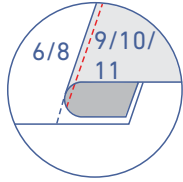
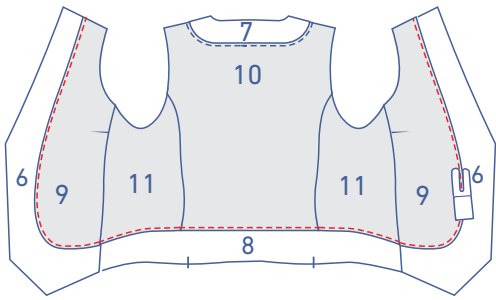

Stitch the lining right next to the seam.

Pin and sew the shoulder seams. Press the seam allowances open.

5

Pin the contours of both waistcoats together neatly, and sew into place.

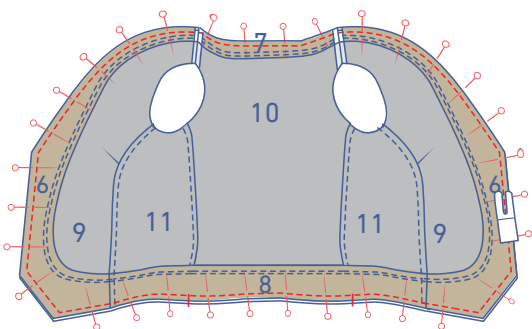
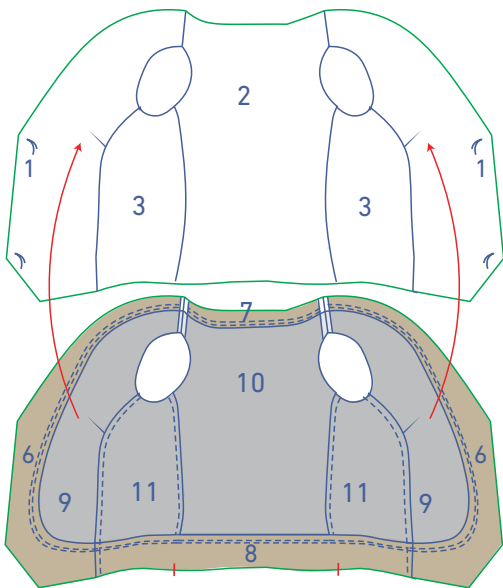

Thin out the seam allowance in the corners, and cut triangles from the back neckline to allow it to lie flat.

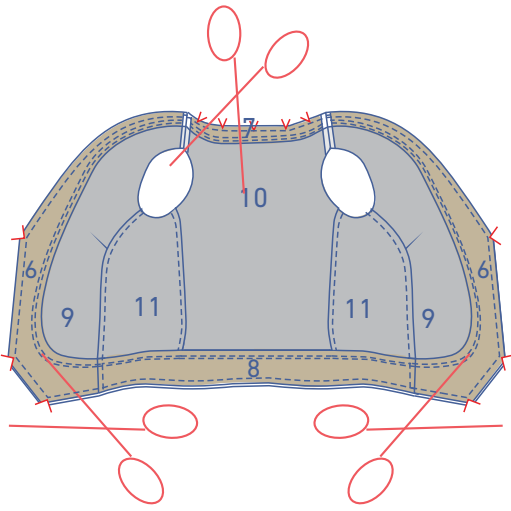

Now stitch the hem facing (6 / 7) to the seam allowance of (1 / 2 / 3). This diagram is for clarity to illustrate the seam line that needs to be stitched; but you need reach through the armhole to access the pieces to be stitched.

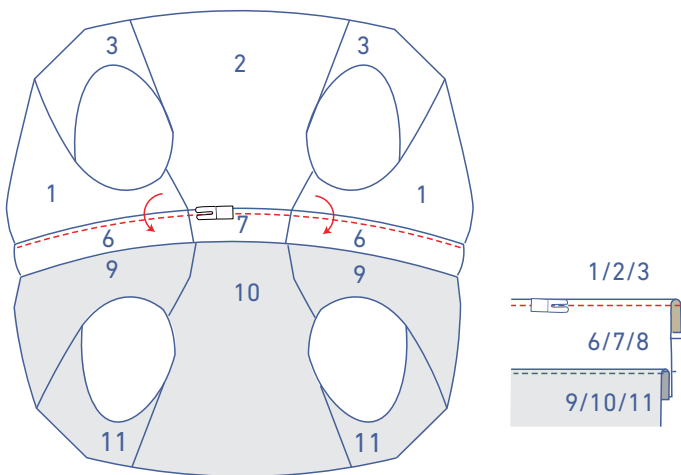

Arrange the armhole of the body/lining into its final position. Now put your hand in the lining hole and pull through the two layers of the armhole (right sides together).

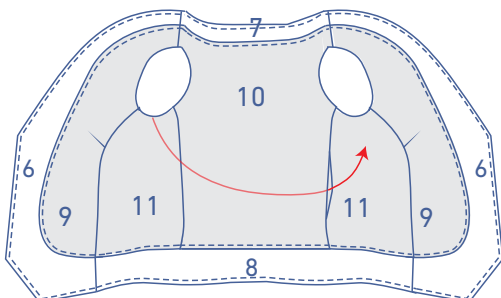
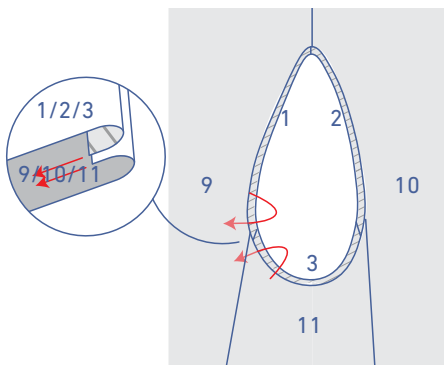

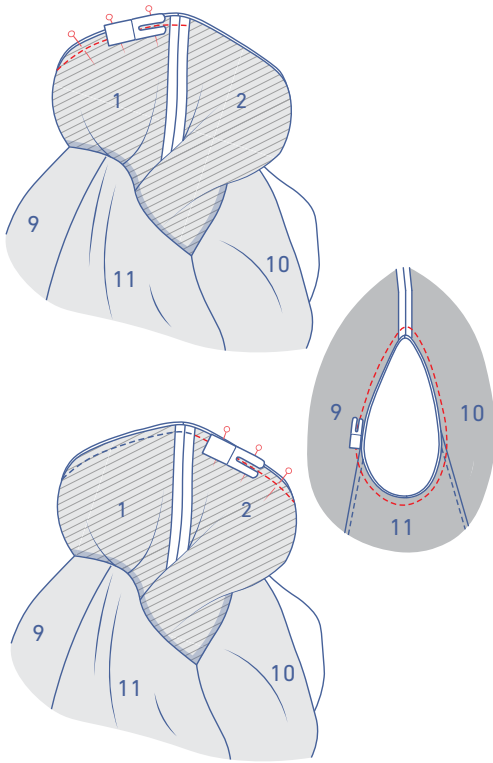

Match the raw edges and sew around the armholes. Do this in 2 cm increments: match the raw edges and sew approx. 2 cm. Line up the raw edges again and sew another 2 cm increment, etc. Continue until you've sewn just past the shoulder seam.

Now, match the seam allowances of the armhole of the other half, past the shoulder seam, and continue sewing from the shoulder (from where you left off) until you've sewn all the way around. This may seem like rather fiddly work, but have faith. You're on the right track as long as you follow these instructions.

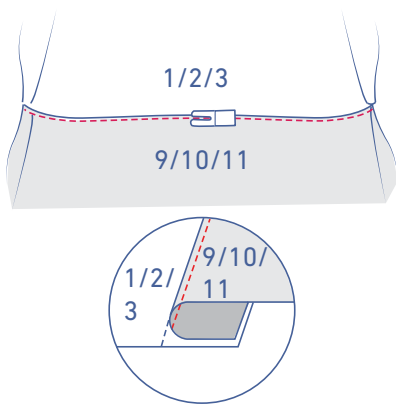

Fold the lining over and sew the lining to the seam allowance underneath right next to the seam (access these pieces via the opening in the lining side seam). Sew off as far as you can. Stop sewing and start again along the other side of the armhole

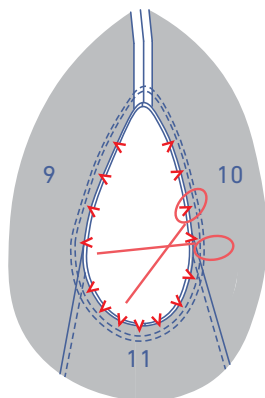

Notch the armhole's seam allowance in several places to allow the curve to lie flat. Without these notches, the seam is likely to tug too much.

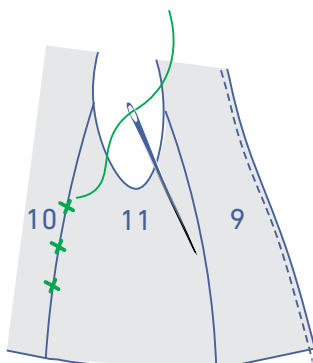

Hand stitch or sew the opening in the seam of the waistcoat lining to close.

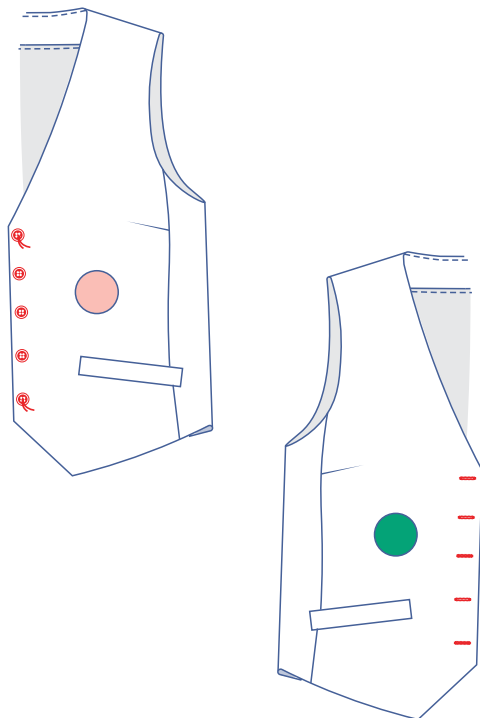

6

Sew the buttons to the LF where indicated. The top and bottom locations have been marked on the pattern for you. To mark the other button locations, evenly divide the distance between the top and bottom fasteners.

Make horizontal buttonholes in the RF to match the buttons.