

Edith by Fibre ⚡ood



Edith by Fibre ood



0 - 28

An understated collar and ruffled trim that drapes across the shoulders – Edith is elegant and versatile. The ruffled trim is completely hackable; make it as long or wide as you like. Edith's elasticised sleeve hems create a subtle puffed effect.

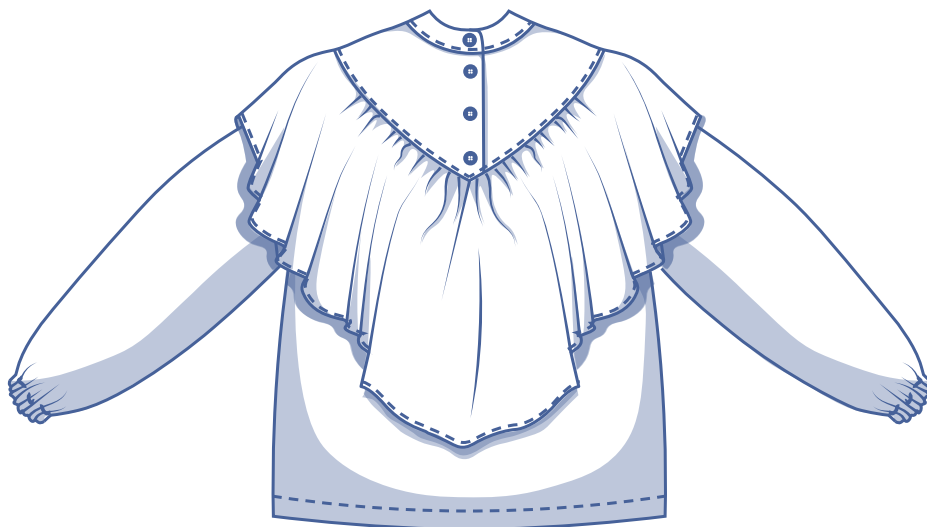
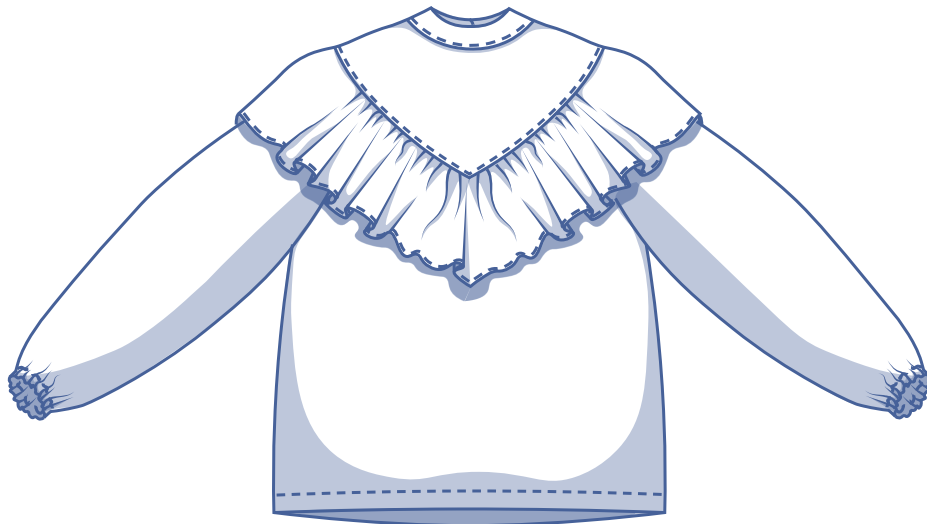

size chart (in inches)

size	0	2	4	6	8	10	12	14	16	18	20	22	24	26	28
body height	5'25"	5'38"	5'45"	5'48"	5'51"	5'54"	5'58"	5'61"	5'64"	5'64"	5'64"	5'64"	5'64"	5'64"	5'64"
B (bust)	29.9	31.5	33.1	34.6	36.2	37.8	39.4	40.9	43.3	45.7	48	50.4	52.8	55.1	57.5
H (hips)	33.9	35.4	37	38.2	39.4	40.6	41.7	42.9	45.3	47.2	49.2	51.2	53.1	55.1	57.1

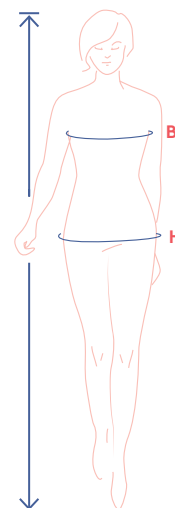

Choose your size based on your **bust measurement**. If your hip measurement is wider than what's listed in the size chart, check the hem circumference in the chart below to see if there's enough room or whether the pattern needs to be altered. It's easy to do. Simply trace the line of the one size instead of the other.

pattern measurements (in inches)

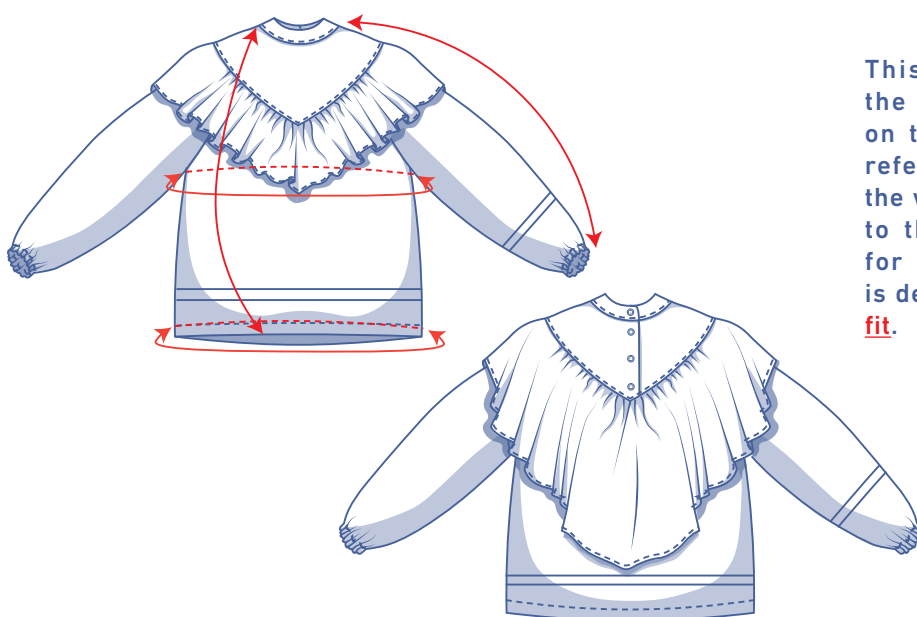

This chart's measurements are the pattern measurements based on the fabric type and serve as a reference. Ease has been added to the width measurements (in addition to the exact body measurements) for a more comfortable fit. Edith is designed to have a **comfy, relaxed fit**.

==== shorten or lengthen the pattern here

size	0	2	4	6	8	10	12	14	16	18	20	22	24	26	28
length	24.7	25	25.2	25.5	25.8	26.1	26.4	26.7	27.1	27.5	27.9	28.3	28.7	29.1	29.5
sleeve length*	27.2	27.4	27.5	27.6	27.8	27.9	28.1	28.2	28.3	28.5	28.7	28.9	29.1	29.2	29.4
bust	34.5	36.1	37.6	39.2	40.8	42.4	43.9	45.5	47.9	50.2	52.6	55	57.3	59.7	62.1
hem circumference	37.1	38.6	40.2	41.8	43.4	44.9	46.5	48.1	50.4	52.8	55.2	57.5	59.9	62.3	64.6

* Including shoulder length.

Compare the stated lengths to the measured or desired lengths. **Lengthen** or **shorten** the top and/or the sleeves by cutting the pattern pieces at the indicated double lines. Then either increase the distance between the cut pieces by the desired amount (to lengthen) or overlap the pieces (to shorten). Make sure that the CF and CB lines and the side seams are always straight.



IMPORTANT

Adjust the amount of fabric to be used based on these alterations.

notions



- Thread
- Iron-on interfacing: max. 2/5 yd
- Button (Ø 7/16"): 4
- Elastic (width 5/8"): see table
- Fabric: see table

elastic		0	2	4	6	8	10	12	14	16	18	20	22	24	26	28
length	yd	1/2	1/2	1/2	3/4	3/4	3/4	3/4	3/4	3/4	3/4	3/4	3/4	3/4	3/4	3/4

fabric		0	2	4	6	8	10	12	14	16	18	20	22	24	26	28
fabric width 43"	yd	2 1/2	2 1/2	2 1/2	3 1/4	3 1/4	3 1/4	3 1/2	3 1/2	3 1/2	3 1/2	3 1/2	3 3/4	3 3/4	4 1/4	4 1/4
fabric width 55"	yd	1 3/4	1 3/4	2 1/4	2 1/4	2 1/4	2 1/4	2 1/4	2 1/4	2 1/2	3 1/4	3 1/4	3 1/2	3 1/2	3 1/2	3 1/2

The corresponding fabric layout can be found on page 6 of these sewing instructions.

fabric advice



Edith looks lovely in all kinds of woven fabric. The ruffled trim will drape gracefully around the shoulders in a soft drape fabric e.g. viscose. In contrast, a stiff fabric will give the ruffled trim more 'bounce' and volume. In other words, you've got a broad palette of fabrics to choose from with Edith, from double gauze, viscose (crepe), chambray, lyocell, poplin, and baby wale corduroy to broderie anglaise. There's also no limit to the prints you can choose from. Think stripes, checks, floral, and more!

Proud to be #Sewista

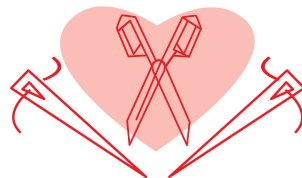

pattern pieces & seam allowances (in inches)

To sew the garment as described in the instructions, draw the illustrated seam allowances around the paper pattern pieces before cutting them out. If you are using a PDF pattern, the pattern can be printed with or without seam allowance. To find out more, watch the [video](#).

1. yoke front: 1x on fabric fold
2. yoke back: 2x
3. bottom piece front: 1x on fabric fold
4. bottom piece back: 1x on fabric fold
5. collar: 2x on fabric fold
6. ruffled trim front: 1x on fabric fold
7. ruffled trim back: 1x on fabric fold
8. sleeve: 2x

TIPS

- The ruffled trim has different widths on front and back. Would you prefer symmetrical ruffled trim? Just cut pattern piece 6 (= the shortest ruffled trim piece) or pattern piece 7 (= the longest ruffled trim piece) twice on the fabric fold.
- Obviously, you're free to decide the width of ruffled trim that you like the best. Tape the shoulder seams of pattern pieces 6 and 7 together and draw the preferred width parallel to the neckline. Add 1 cm of seam allowance.

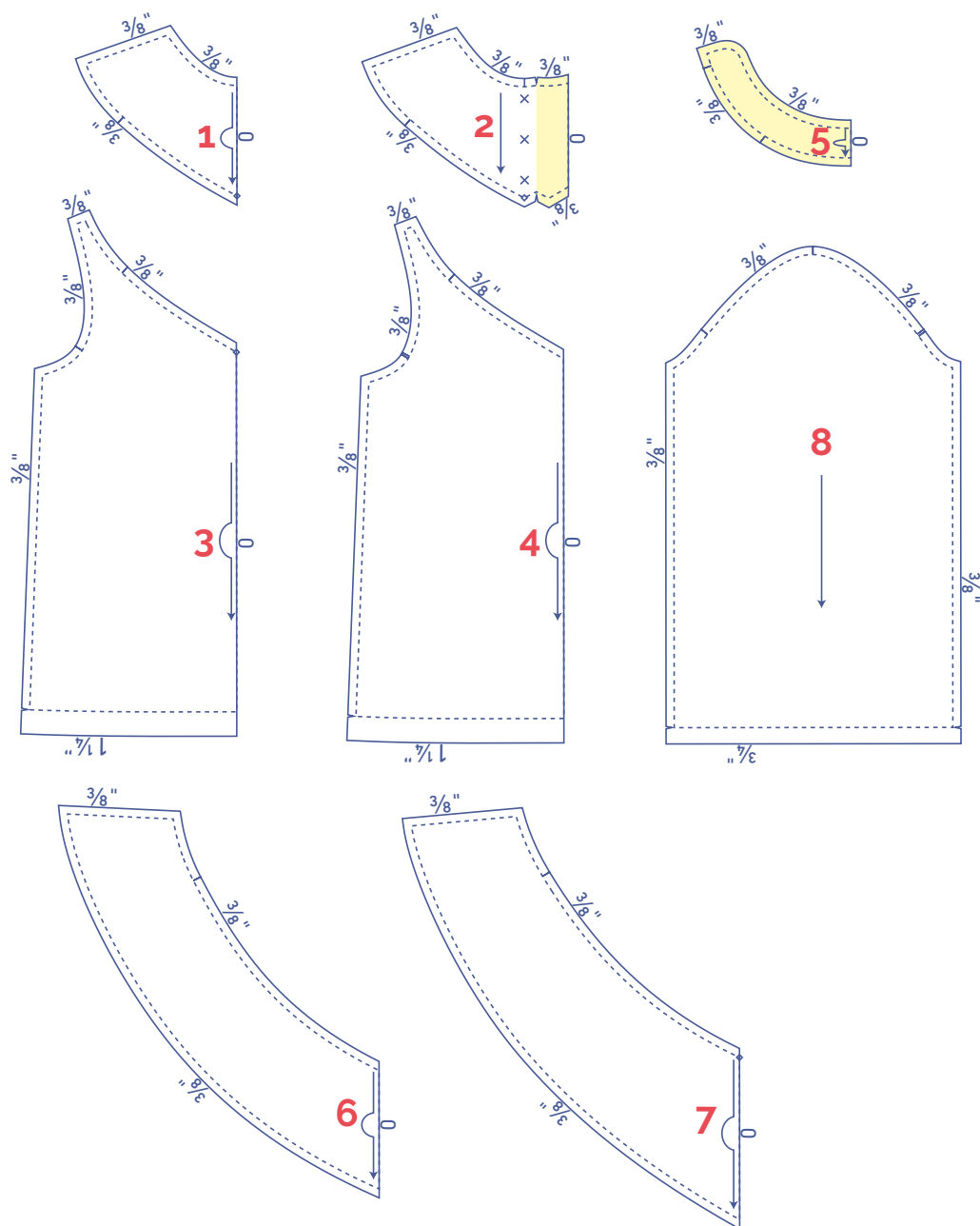

IMPORTANT

The pieces highlighted in light yellow have iron-on interfacing attached to the wrong side.

?	material type
□	fabric
■	iron-on interfacing

fabric layout – solid fabrics
fabric width 43"

0 - 4

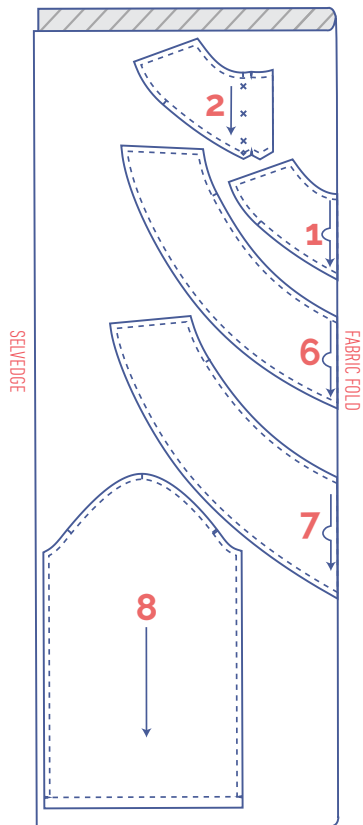
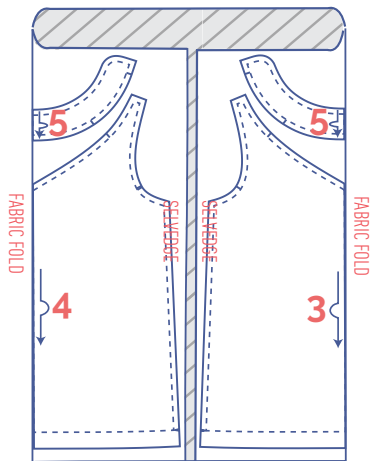

6 - 24

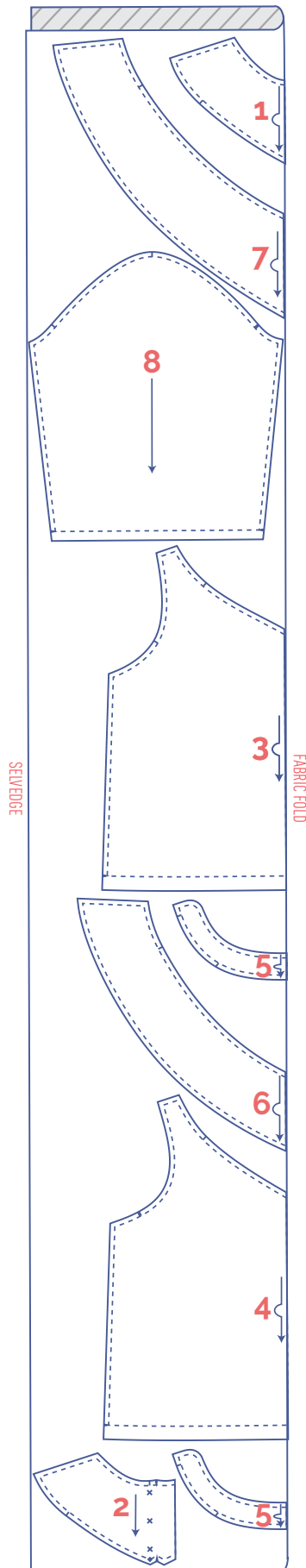

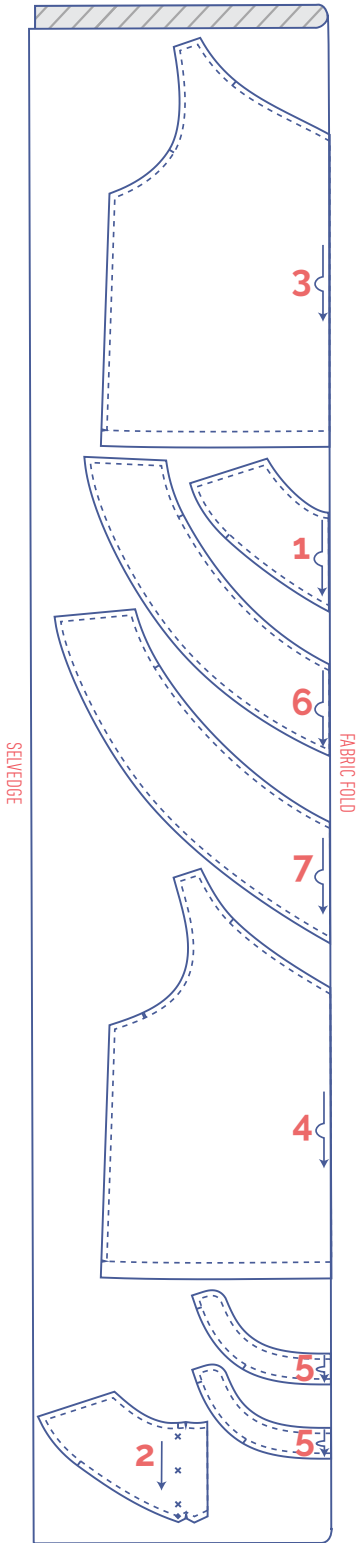

+

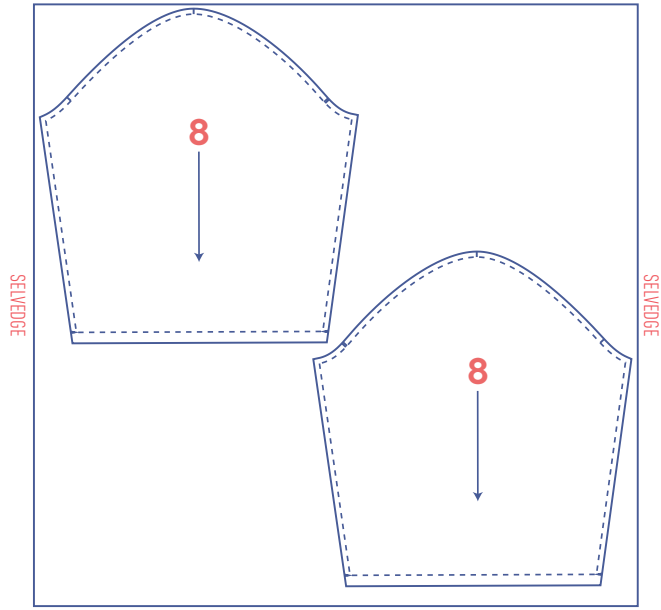

fabric layout – solid fabrics fabric width 55"

0 - 2

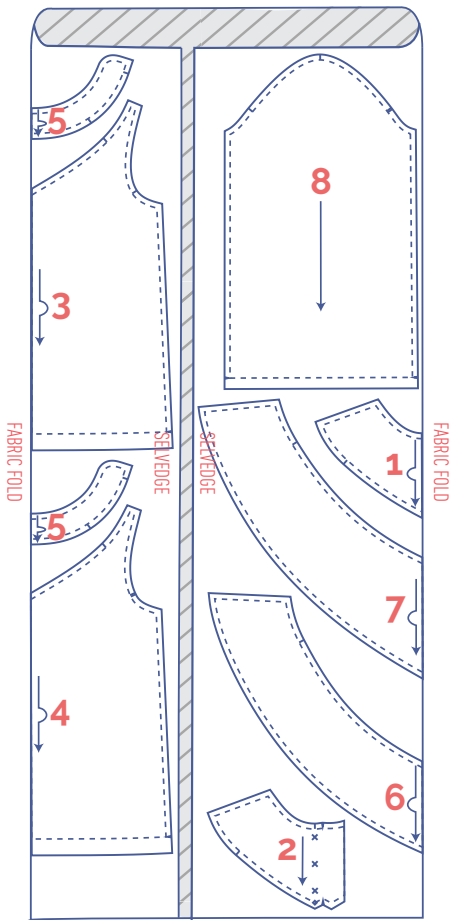

4 - 16

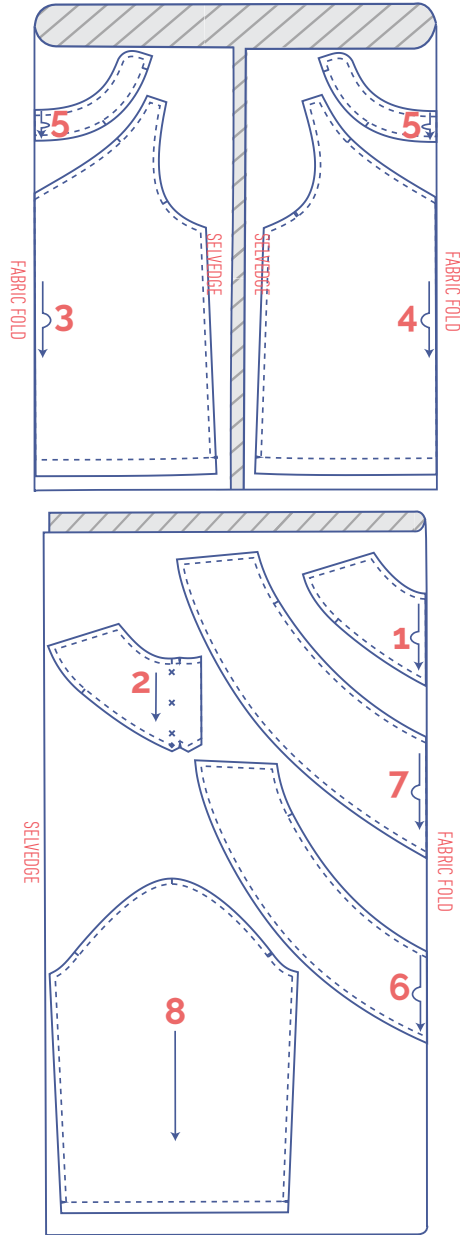

18 - 28

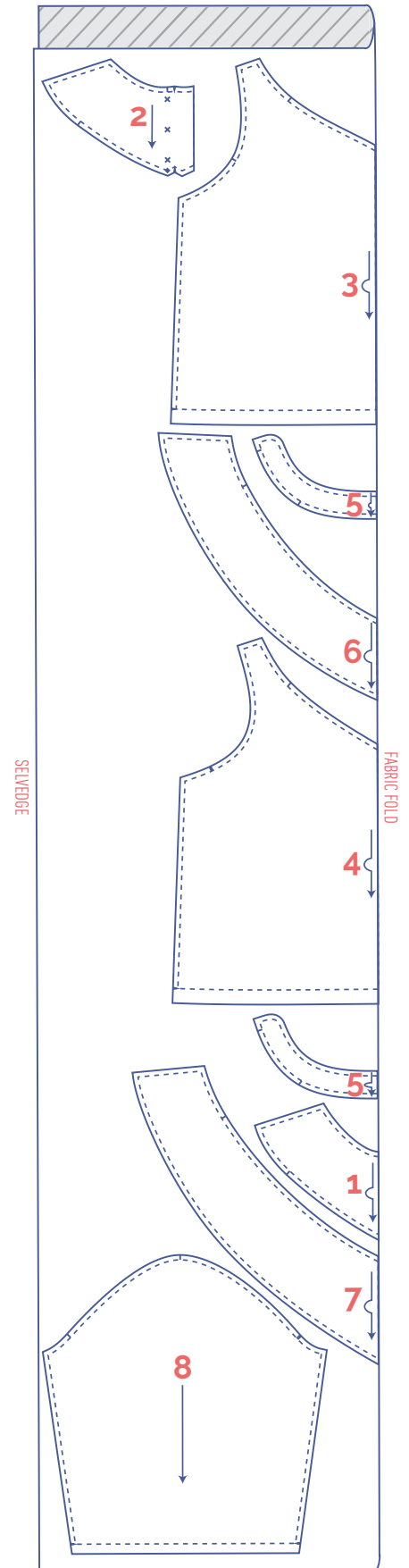

marking pattern pieces

 notch the pattern paper and fabric at the following points

| single notch

|| double notch

V V notch

 mark the following points with marking thread

 centre point

 snap fastener

sewing instructions



The method used to finish the seams depends on the fabric used. The pieces are always sewn together with the right sides of the fabric facing, unless stated otherwise.

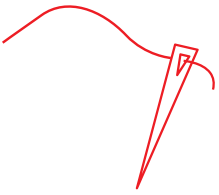

F	front
B	back
CF	centre front
CB	centre back
	right side
	wrong side
	iron-on interfacing

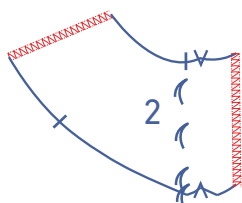
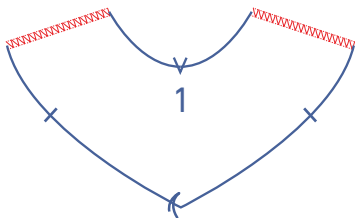
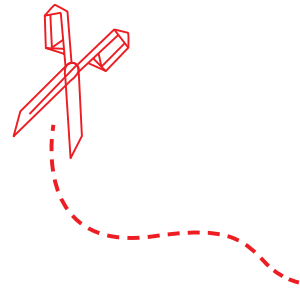

1

Finish the edges of the yoke front (1) and yoke back (2) with overlock stitching where indicated.

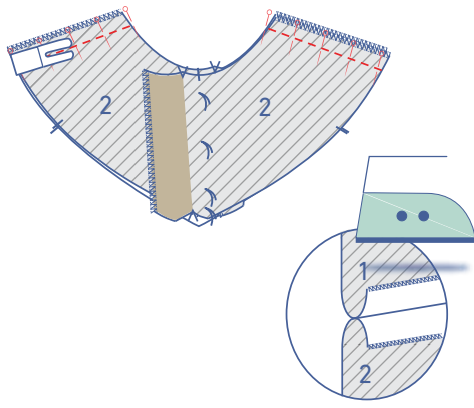

Pin and sew the shoulder seams of the yoke. Press the seam allowances open.

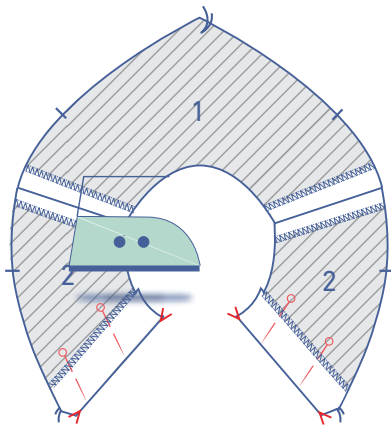

Neatly press the facing towards the wrong side at the V notches and pin temporarily into place.

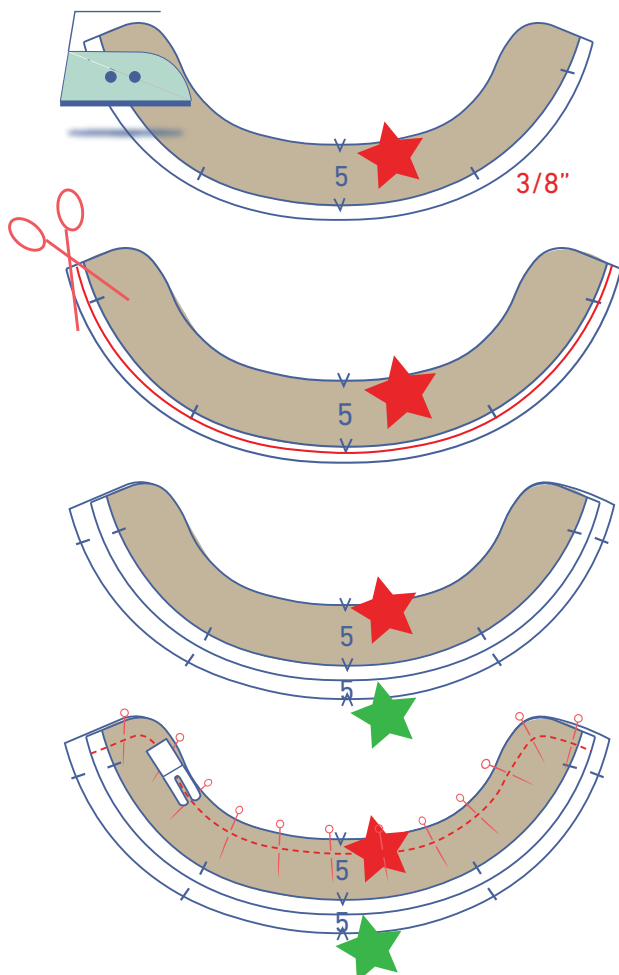

2

Press the bottom of one of the collar pieces (5) $\frac{3}{8}$ " towards the wrong side. We've marked this collar piece with a red star.

Trim the excess seam allowance. Appliqué scissors are useful here if you have them.

Place the red star collar piece on top of the green star collar piece (= the collar that has not been pressed at the bottom), right sides together.

Pin and sew the contours where indicated.

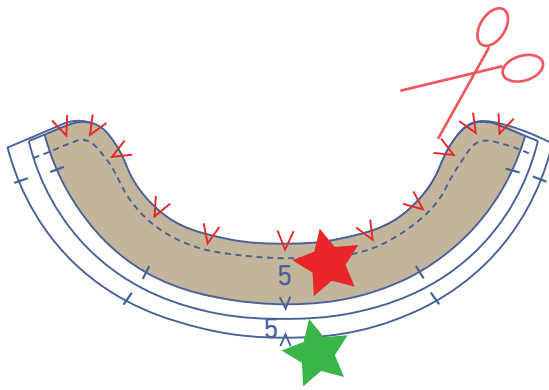

Trim the seam allowances so the curve can lie flat when turned out.

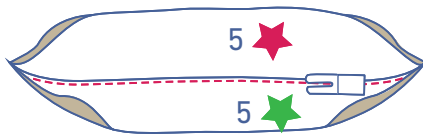

Open out the collar pieces. Fold the seam allowance towards the green star collar piece. Sew the green star collar to the seam allowance underneath right next to the seam.

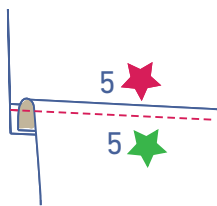

Pin and sew the green star collar to the neckline along the wrong side of the top, matching notches.

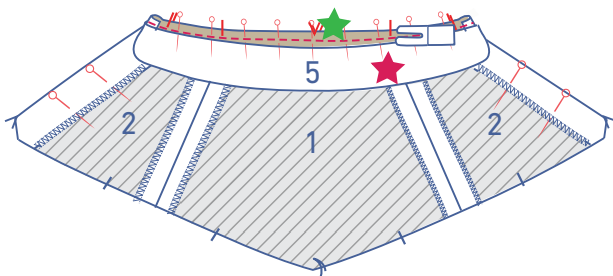

Fold the collar up. The fold line of the red star collar should be directly on top of the previous stitching. Pin and sew into place.

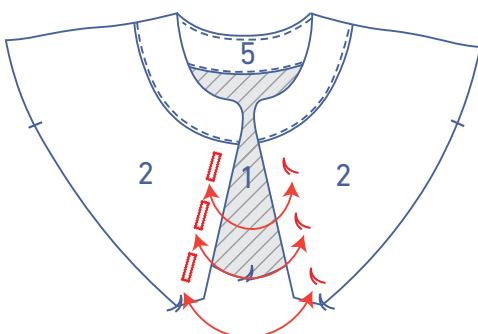
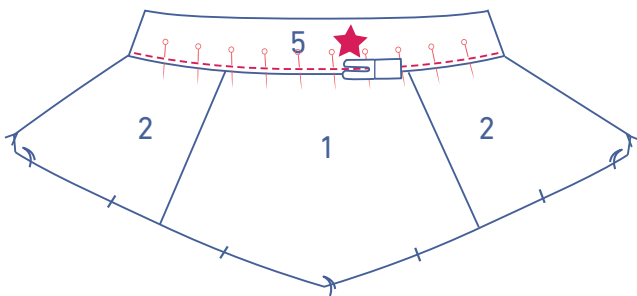

3

Make vertical buttonholes where indicated on the yoke to match the buttons. The positions of the buttons have been indicated on the pattern for you.

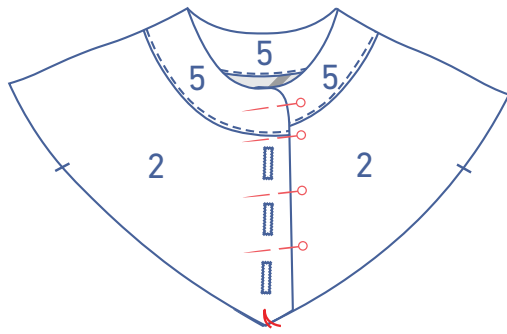

Place the yoke with buttonholes over the other yoke piece, matching the marking threads. Pin to secure these pieces together.

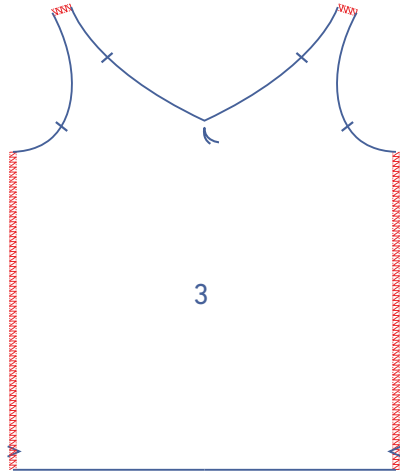

4

Finish the edges of the bottom piece front (3) and bottom piece back (4) with overlock stitching where indicated.

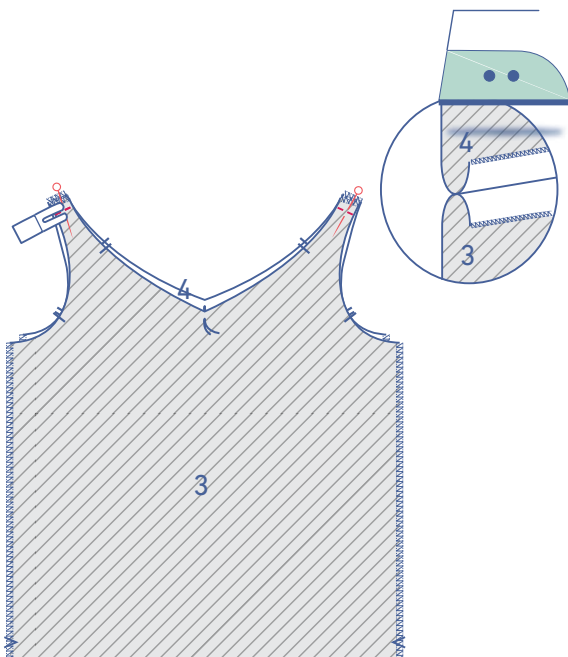
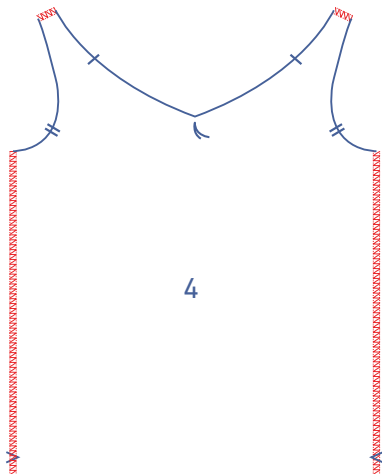

Pin and sew the shoulder seams of the bottom piece. Press the seam allowances open.

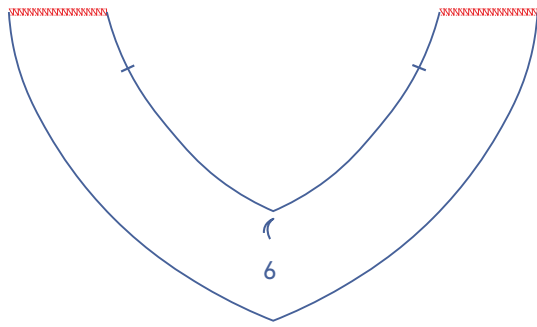

Finish the ends of the ruffled trim front (6) and ruffled trim back (7) with overlock stitching where indicated.

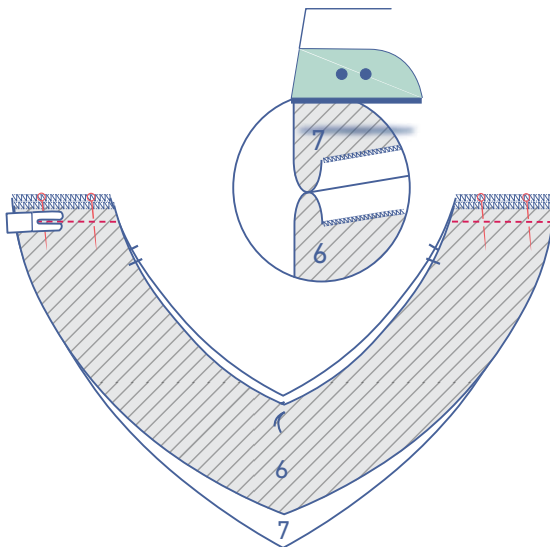
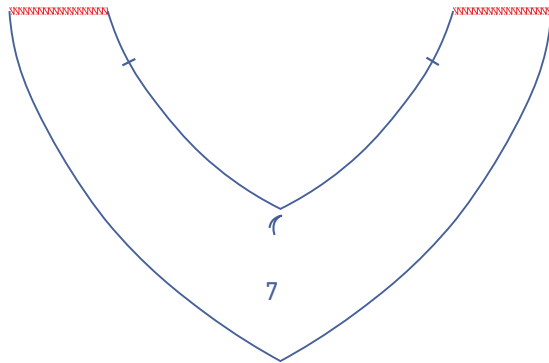

Pin and sew the shoulder seams of the ruffled trim together. Press the seam allowances open.

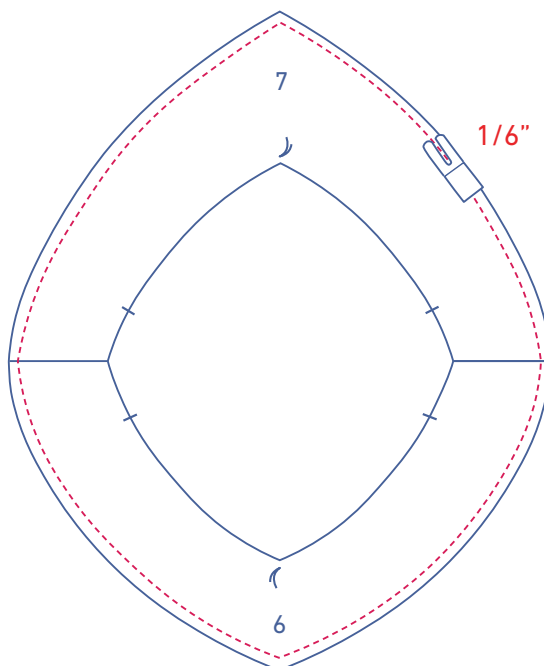

5

Finish the bottom of the ruffled trim as follows: sew at 1/6" from the unnotched raw edge.

Press the raw edge along the stitching towards the wrong side.

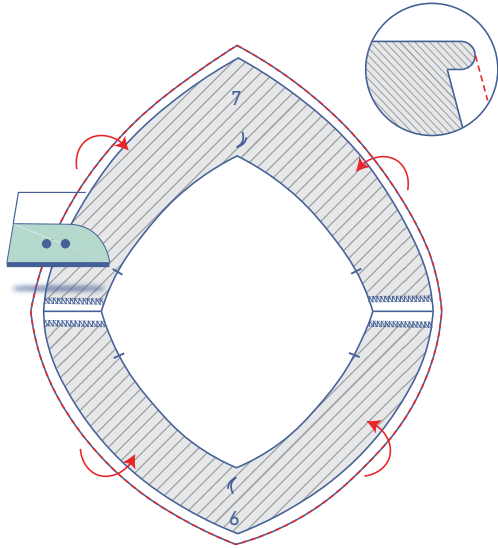

Sew the pressed seam allowance into place at 1/8" from the edge.

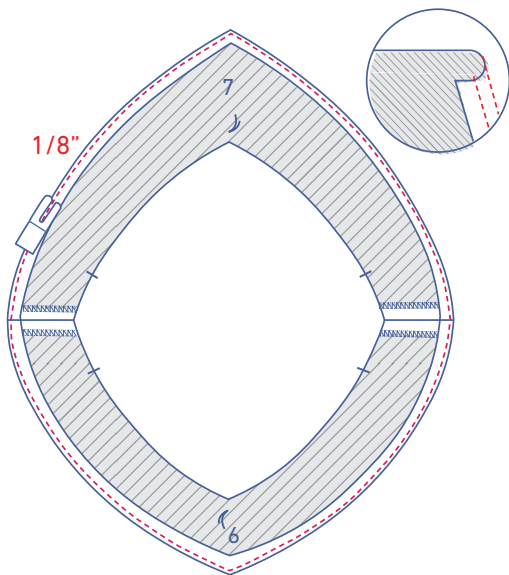

Trim any excess seam allowance.

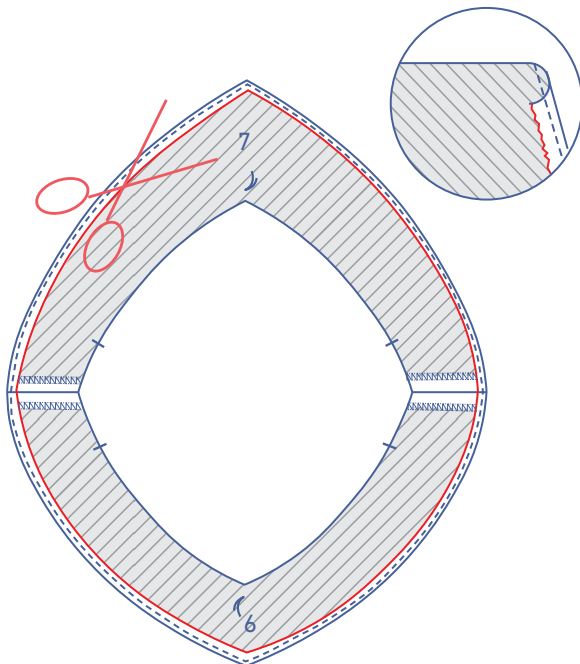

Fold the edge over again towards the wrong side and sew into place. Neatly press along the wrong side.

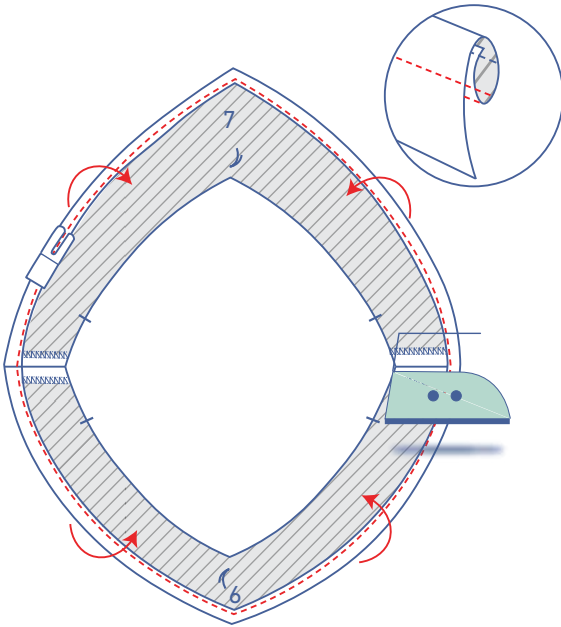

6

Using a long stitch length at a low thread tension, sew two lines of parallel stitching at the top (= unfinished raw edge) of the ruffled trim until just past the indicated notches. Leave a length of thread at the start and end of the stitching.

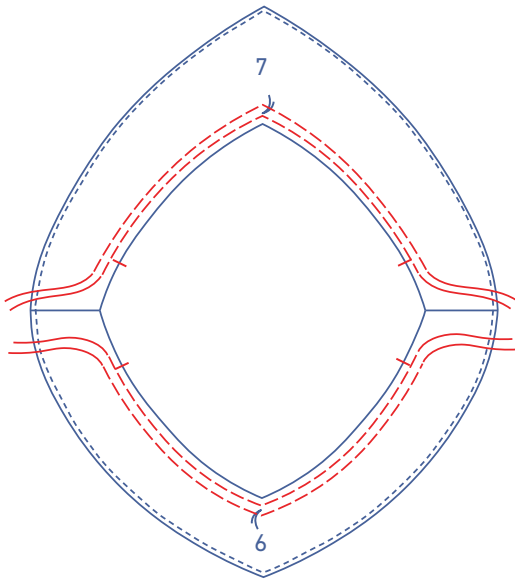

Gently tug the ends of the threads to gather the fabric.

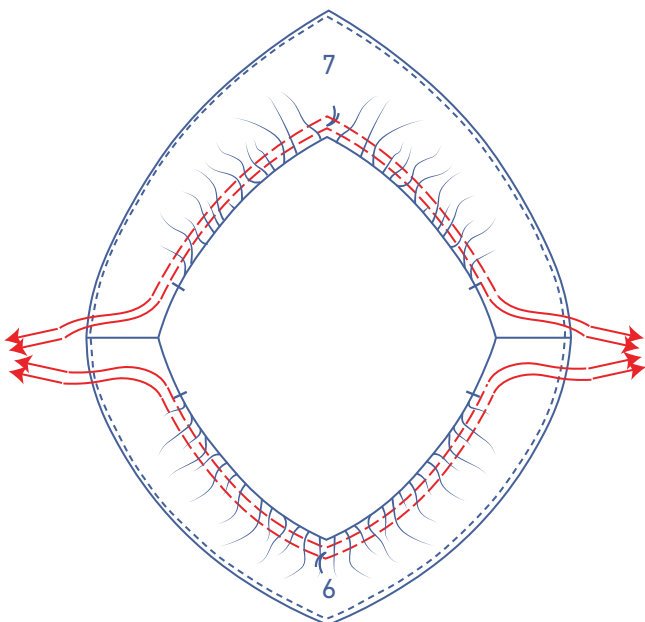

Distribute the gathers so that the ruffled trim notches match the notches in the bottom piece.

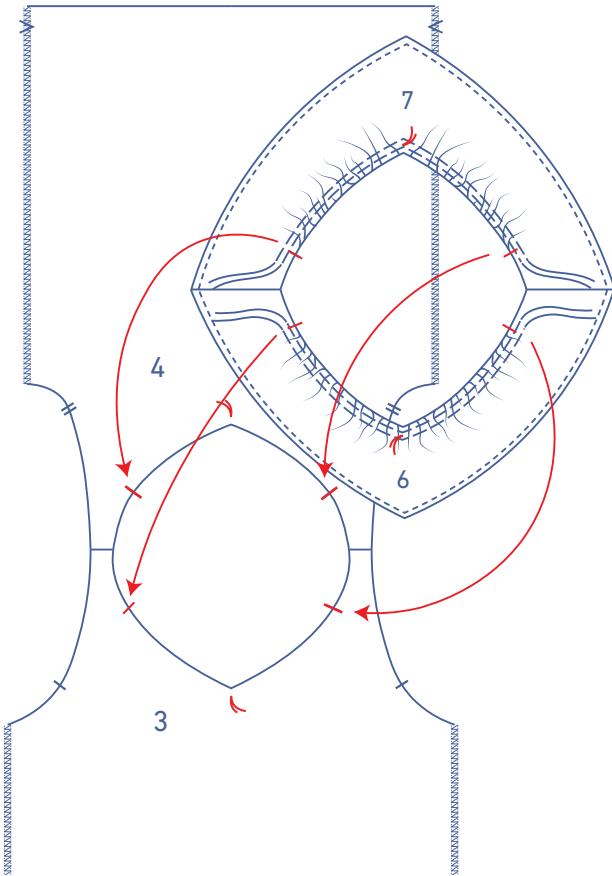

Pin the ruffled trim to the bottom piece, matching the markings. Sew into place at 1/6" from the raw edges. Note that the wrong side of the ruffled trim is touching the right side of the bottom piece.

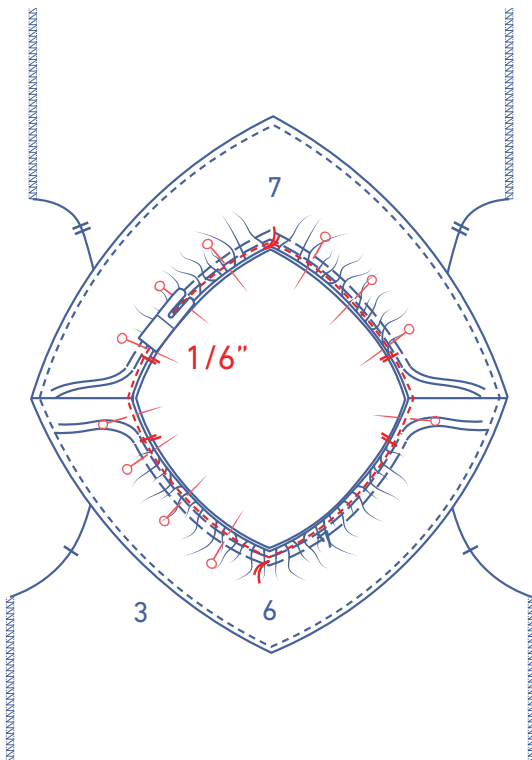

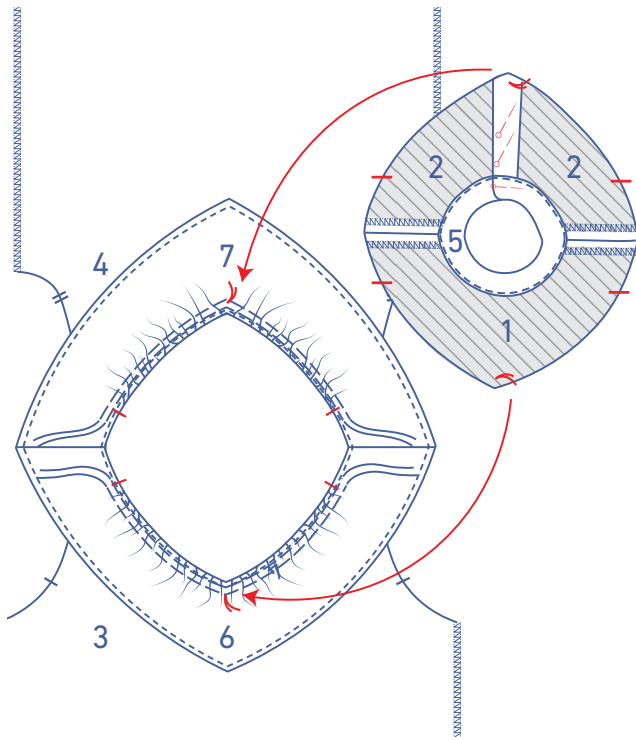

7

Pin the yoke to the bottom piece + ruffled trim, matching the marking threads and notches.

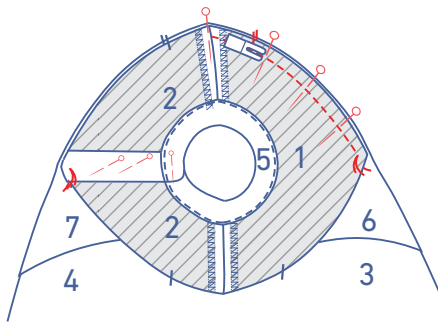

Starting at the shoulder seam, sew up to the marking thread and leave the needle in the fabric there.

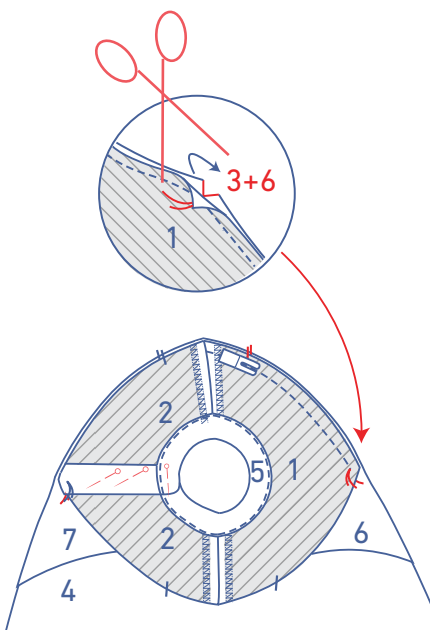

Raise the presser foot, fold the seam allowance of the yoke out of the way and snip into the seam allowance of the bottom piece + ruffled trim until right before the marking thread. Turn the garment and lower the presser foot back down.

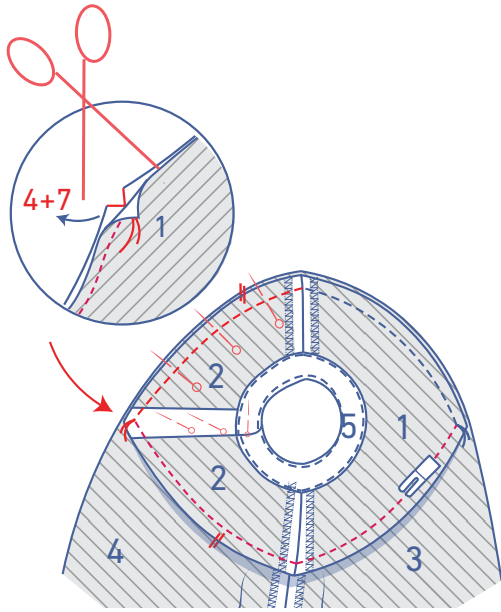

Pin and sew up to the next marking thread and repeat the previous steps on the other side of the garment. Continue sewing until you've sewn all the way around.

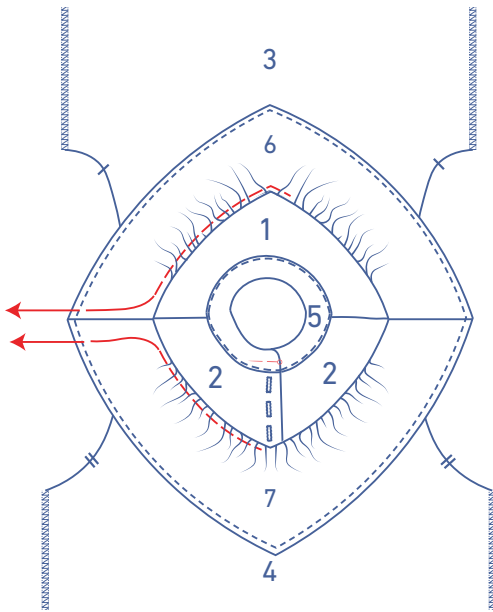

Then, remove the gathering threads.

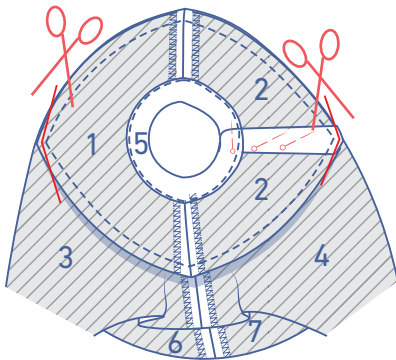

Snip into the seam allowance at the tip of the V as shown.

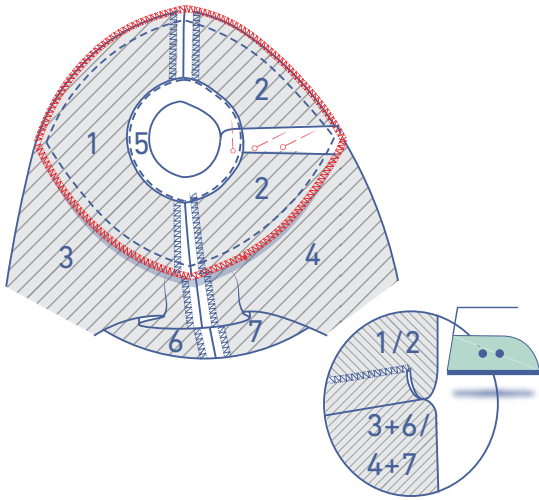

Finish the raw edges and press the seam allowance towards the yoke.

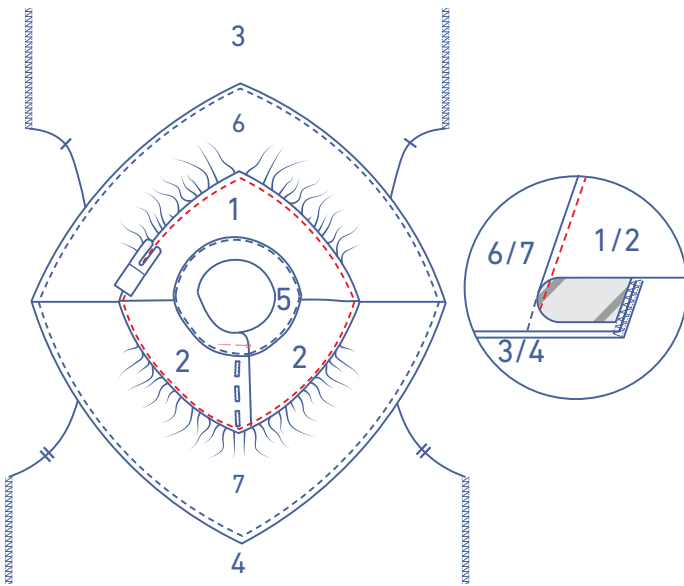

Sew the yoke to the seam allowance underneath, right next to the seam.

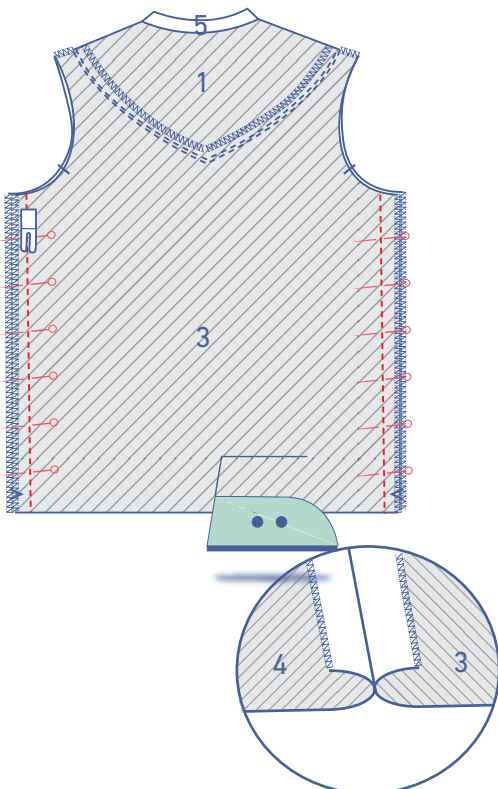

8

Pin and sew the side seams together. Press the seam allowances open.

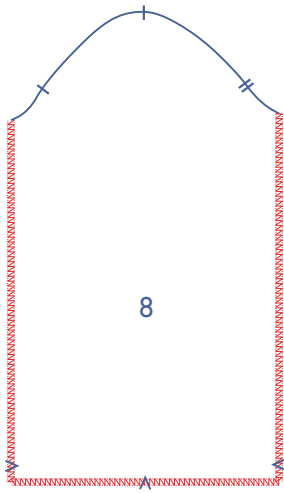

9

Finish the bottom and sides of the sleeve (8) with overlock stitching.

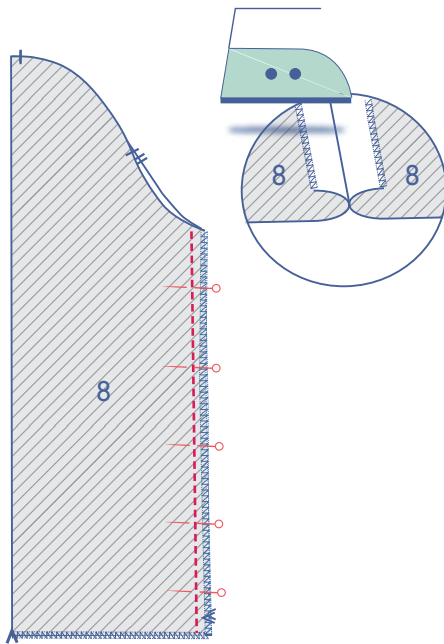

Pin and sew the underarm seam. Press the seam allowances open.

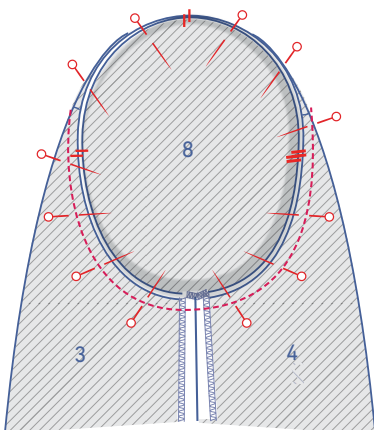

Pin the top of the sleeve (= the sleeve cap) to the armhole, matching the notches. The single notch marks the front, while the double notch marks the back. The single notch at the top lines up with the shoulder seam. Distribute the excess fabric between the notches at the top and sew into place. Be careful not to snag or sew any puckers.

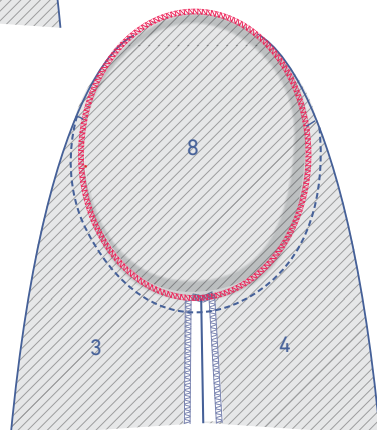

Finish the raw edges with overlock stitching.

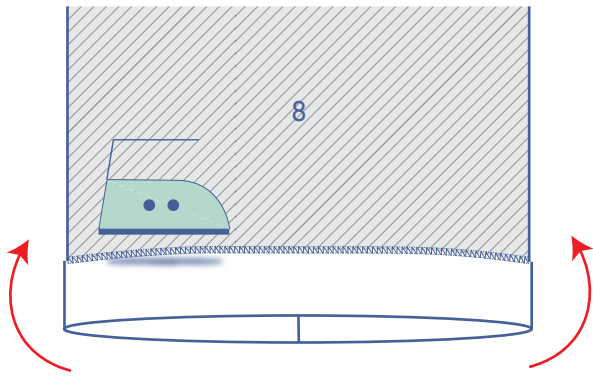

Press the bottom of the sleeve over at the V notches.

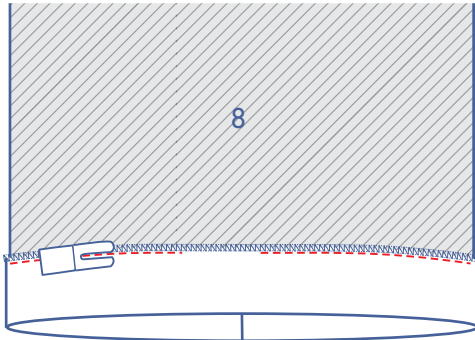

Make a casing by topstitching right next to the edge, leaving a gap through which to thread the elastic later.

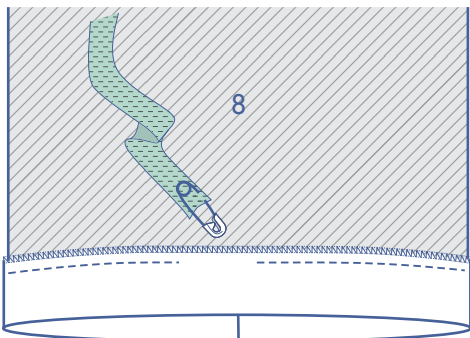

Thread the elastic through the casing via the opening.

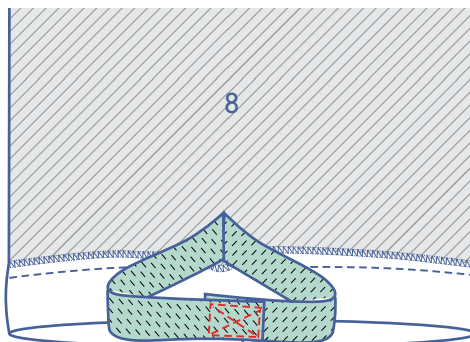
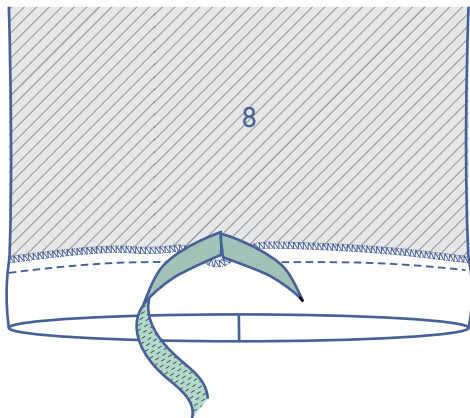

Overlap 1 1/4" of the ends and sew into place with a Box X stitch.

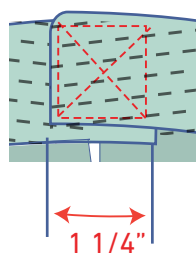

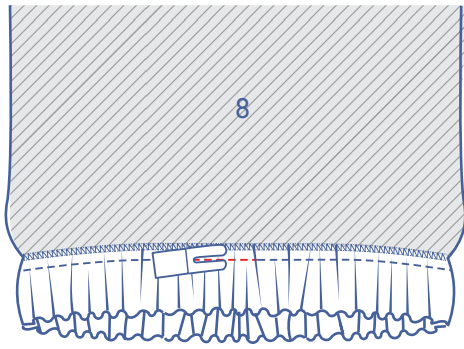

Tuck the elastic back neatly into the casing and sew the opening closed.

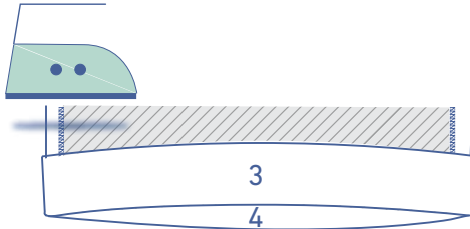

10

Press the hem allowance up at the V notches and then open back out.

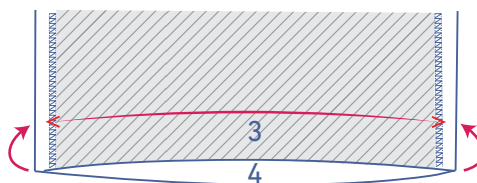
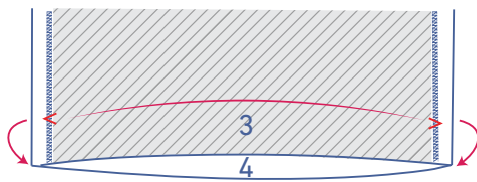

Match the raw edge to the pressed fold line and fold up again.

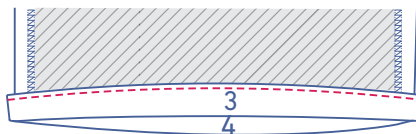
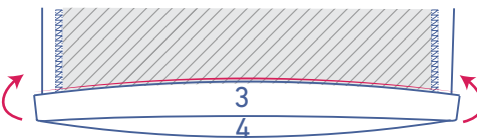

Sew into place next to the edge.

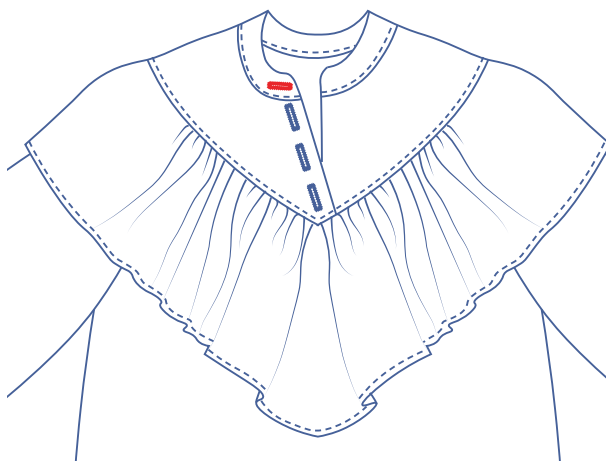

11

Make a horizontal buttonhole at the indicated end of the collar band halfway up and at 3/8" from the finished edge.

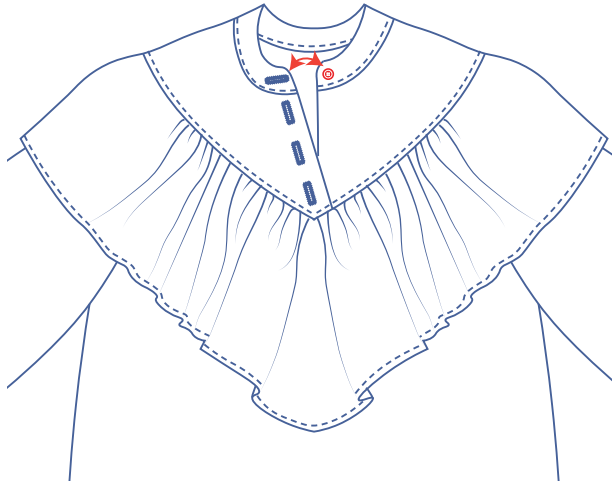

Sew a button on at the other end to match.

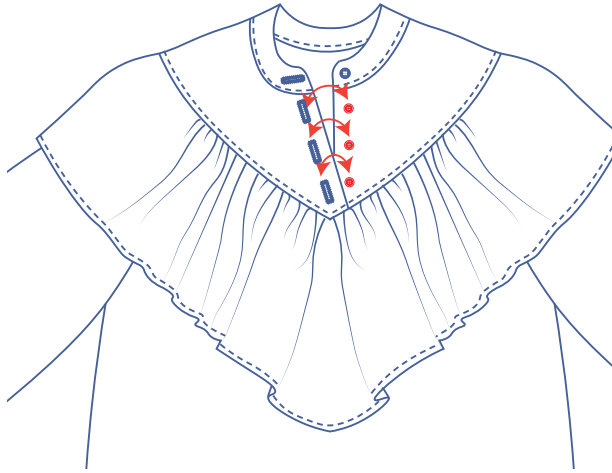

Finish by sewing the remaining buttons on to match the buttonholes.